

# 305U Ductile Iron UL/FM Gate Valve • Spec Sheet



## FEATURES & BENEFITS

- Resilient Wedge
- AWWA C515 & UL/FM Approved
- Flanged Ends - Conforms with ASME B16.1 Class 125
- Fusion Bonded Epoxy Coating – Complies with ANSI / AWWA C550
- ANSI/NSF 61 & ANSI/NSF 372 Approved
- Rising Stem (OS&Y)
- 300 PSI / Max Temp 230° F
- 4 Bosses - 1 Tapped with Plug
  - 3" & 4" - 1/2" Brass Plug
  - 6" & Up - 3/4" Brass Plug
- Sizes 2-1/2" – 12"

## DIMENSIONS

Part #	Size	L	H1 (Close)	H2 (Open)	D	D1	C	n-ØL	# of Holes
305U09	2-1/2"	7.49	14.70	17.34	7.01	5.50	0.69	0.75	4
305U10	3"	8.00	16.08	19.31	7.53	6.00	0.75	0.75	4
305U11	4"	9.02	18.56	22.58	9.02	7.51	0.75	0.75	8
305U13	6"	10.52	23.68	29.75	10.99	9.51	0.75	0.87	8
305U14	8"	11.50	30.50	38.42	13.51	11.76	0.87	0.89	8
305U15	10"	13.00	37.00	47.00	16.00	14.26	0.94	1.00	12
305U16	12"	14.03	41.96	53.98	19.03	17.01	1.00	1.00	12

## MATERIAL SPECIFICATIONS

No.	Part	Material
1	Body	Ductile Iron A536, 65-45-12
2	Wedge	Ductile Iron, EPDM Encapsulated
3	Stem	Stainless Steel AISI 420
4	Bonnet Gasket	EPDM
5	Bonnet	Ductile Iron A536, 65-45-12
6	Stem Packing	EPDM
7	Yoke	Ductile Iron A536, 65-45-12
8	Stem Bushing	Brass Hpb59-1
9	Gland	Ductile Iron A536, 65-45-12
10	Stem Nut	Brass Hpb59-1
11	Handwheel	Ductile Iron A536, 65-45-12
12	Washer	Brass Hpb59-1
13	Gland Nut	Stainless Steel AISI 304
14	Stud	Stainless Steel AISI 304
15	Flat Washer	Stainless Steel AISI 304
16	Nut	Stainless Steel AISI 304
17	O-Ring	EPDM

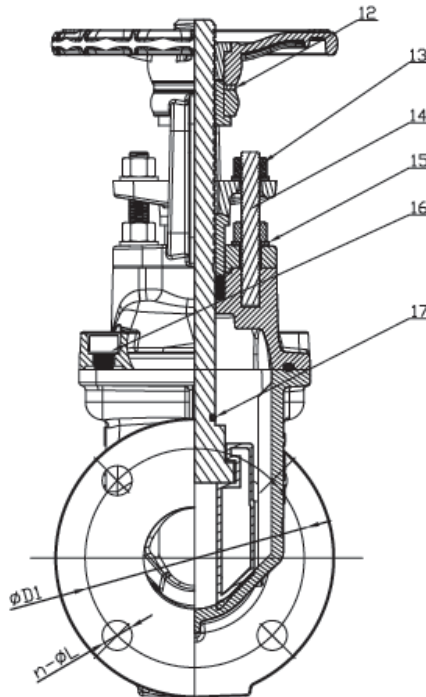
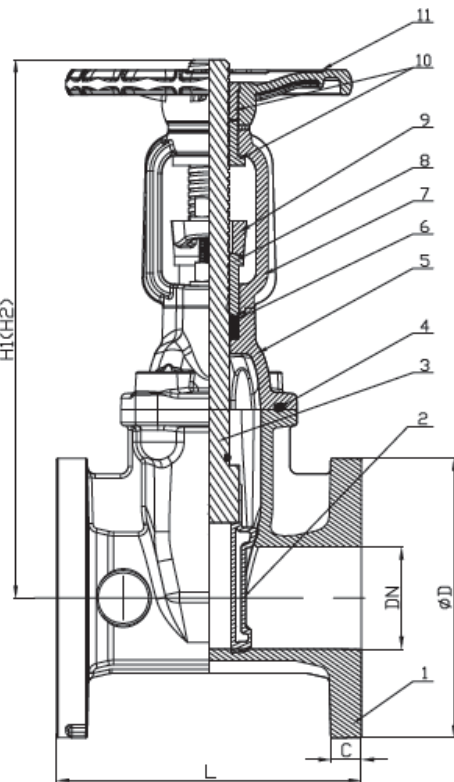

**MATCO-NORCA**

Global sourcing. National compliance. Local service.

**CALIFORNIA** 5595 Fresca Dr., La Palma CA 90623  
**TEXAS** 1150 Silber Rd., Houston TX 77055  
**ILLINOIS** 278 Windy Point Dr., Glendale Heights, IL 60139  
**GEORGIA** 113 Industrial Blvd., Americus, Georgia 31709  
**NEW YORK** PO Box 27, Rt.22, Brewster NY 10509  
 WEB: [www.matco-norca.com](http://www.matco-norca.com)

• Phone: 866-532-8306 • Fax: 866-532-8307  
 • Phone: 800-935-5456 • Fax: 713-680-2999  
 • Phone: 844-412-5068 • Fax: 800-640-2252  
 • Phone: 800-433-7526 • Fax: 800-533-5134  
 • Phone: 800-431-2082 • Fax: 845-278-9056  
 EMAIL: [mail@matco-norca.com](mailto:mail@matco-norca.com)