

200TVD Ductile Iron Tapping Valve • Spec Sheet



FEATURES & BENEFITS

- Mechanical Joint X Flange w/ Alignment Lip
- Conforms w/ AWWA C515
- ISO-9002
- 250 PSI CWP
- NSF Approved Fusion Bonded Epoxy
- Conforms to MSS SP-60
- EPDM Resilient Wedge
- Non Rising Stem
- Oversized Ports
- Bolted Bonnet
- Operating Nut
- Sizes 3" - 12"

Applications: Waterworks, For Use When Tapping Pressurized Lines

DIMENSIONS

Size	DN	L	B	C	D	E	H	M	G	Approx Wt. LBS
3"	3.31	8.98	4.06	4.94	7.49	8.35	12.84	7.49	0.75	47.3
4"	4.27	9.73	4.91	6.02	9.10	9.69	14.18	9.10	0.94	62.7
6"	6.28	11.19	7.01	8.13	11.07	13.00	17.61	11.07	1.00	107.4
8"	8.29	11.74	9.16	10.28	13.51	16.15	20.76	13.51	1.13	172.7
10"	10.28	13.51	11.21	12.35	16.00	13.00	17.61	16.00	1.18	261.8
12"	12.27	14.78	13.31	14.45	18.99	16.15	20.76	18.99	1.22	374

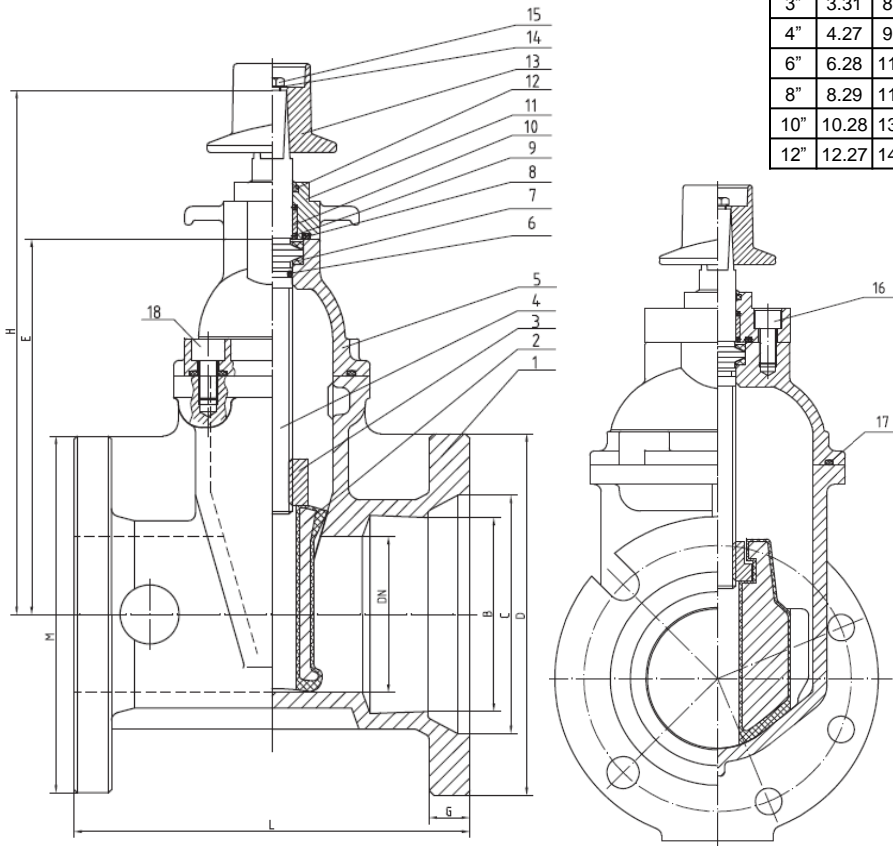

MATERIAL SPECIFICATIONS

No.	Part	Material
1	Body	Ductile Iron A536
2	Wedge	Ductile Iron ASTM A536 / EPDM ASTM D2000
3	Stem Nut	Bronze ASTM B584
4	Stem	Stainless Steel AISI 410
5	Bonnet	Ductile Iron ASTM A536
6	Stem Primary O-Ring	EPDM ASTM D2000
7	Stem Gasket	Nylon 1010
8	Gland Seal O-Ring	EPDM ASTM D2000
9	Stem Secondary O-Ring	EPDM ASTM D2000
10	Stem Seal Bushing	Nylon 1010
11	Packing Gland	Ductile Iron ASTM A536
12	Dustproof Ring	EPDM ASTM D2000
13	Operating Nut	Ductile Iron ASTM A536
14	Washer	Stainless Steel AISI 410
15	Bolts	Stainless Steel AISI SS304
16	Gland Bolts	Stainless Steel AISI SS304
17	Bonnet Gasket	EPDM ASTM D2000
18	Bonnet Bolts	Stainless Steel AISI SS304

MATCO-NORCA
Global sourcing. National compliance. Local service.

CALIFORNIA 5593 Fresca Dr., La Palma CA 90623 • Toll Free: 866-532-8306 • Fax: 866-532-8307
TEXAS 1150 Silber Rd., Houston TX 77055 • Toll Free: 800-935-5456 • Fax: 713-680-2999
NEW YORK PO Box 27, Rt. 22, Brewster NY 10509 • Toll Free: 800-431-2082 • Fax: 845-278-9056
 WEB: www.matco-norca.com EMAIL: mail@matco-norca.com