

PA-400C
 PA-400ORB

PA-400BN



4" Two Handle Lavatory Faucet



FEATURES & BENEFITS

- This Product Contains Less Than 0.25% Weighted Average Lead Content On Wetted Surfaces
- Metal Lever Handles
- Ceramic Cartridges
- Brass Pop-up
- Max Flow Rate 1.2 GPM (4.5 L/MIN) At 60 PSI (ASME A112.18.1M/A112.18.1)

PA-400C
Chrome Finish

PA-400BN
Brushed Nickel Finish

PA-400ORB
Oil Rubbed Bronze Finish

APPROVALS:

Meets or Exceeds The Following:

- * ANSI/ASME A112.18.1M/A112.18.1
- * NSF/ANSI 61 - Sec. 9
- * NSF/ANSI 372
- * IAPMO/cUPC
- * CA AB1953



NSF/ANSI 372
NSF/ANSI 61-9



CALIFORNIA:
TEXAS:
NEW YORK:

TEL: 866-532-8306
TEL: 800-935-5456
TEL: 800-431-2082

FAX: 866-532-8307
FAX: 800-683-4247
FAX: 800-640-2252

Visit Our Web Site : www.matco-norca.com

Product Spec Sheet

□ **PA-400C**

□ **PA-400BN**



□ **PA-400ORB**

4" Two Handle Lavatory Faucet

No.	Name	Part No.
1.1	Index Button-Cold	A66D575C
1.2	Index Button-Hot	A66D575H
2.1	Metal Handle Assembly-Cold	A662296C
2.2	Metal Handle Assembly-Hot	A662296H
3	Retainer Nut Assembly	A663631
4.1	Ceramic Disc Cartridge-Cold	A507104N
4.2	Ceramic Disc Cartridge-Hot	A507103N
5	Lift Rod	A025131
6	Putty Plate	A011012
7	Lock Nut	A504023
8	Aerator	A500268N-64
9	Pop-up Assembly	A556200

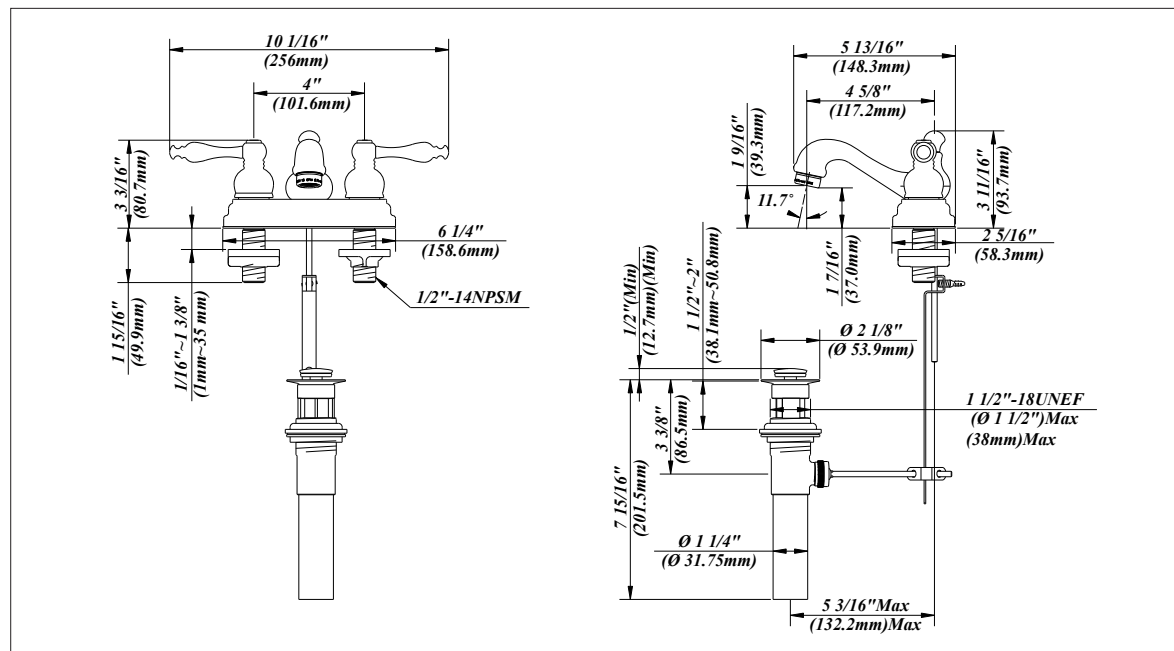
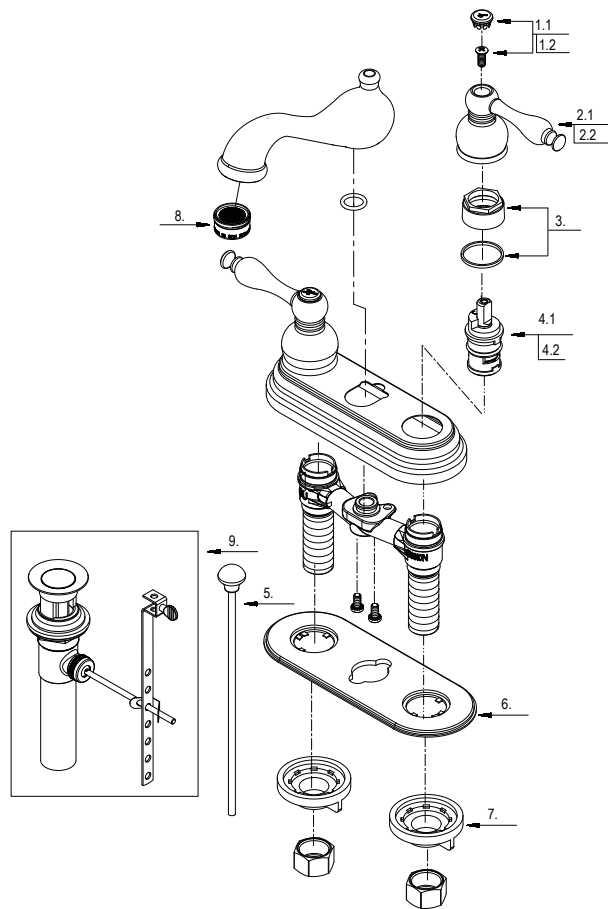

Product Spec Sheet

CALIFORNIA:
TEXAS:
NEW YORK:

TEL: 866-532-8306
TEL: 800-935-5456
TEL: 800-431-2082

FAX: 866-532-8307
FAX: 800-683-4247
FAX: 800-640-2252

Visit Our Web Site : www.matco-norca.com