

# P759EXT STEM EXTENSION

## Specification Sheet

### FEATURES & BENEFITS

- 759 Ball Valve Stem Extension
- Fits IPS & SWT Standard Valve
- 1/2" & 3/4" Height Increased 2.17 in.
- Does Not Fit the 759 Press Ball Valves



### DIMENSIONS

Part #	Size	A	B	C	D	E	F
P759EXT03	1/2"	2.05	0.55	4.14	0.51	14 NPT	3.70
P759EXT04	3/4"	2.30	0.57	4.14	0.71	14 NPT	3.95

### MATERIAL SPECIFICATIONS

No.	Part	Material
1	Screw	Steel
2	Washer	Local Brass
3	Handle	Steel
4	Heightened Stem Part 1	Local Brass
5	Hex-nut	Local Brass
6	Heightened Stem Part 2	Local Brass
7	Packing Nut	Local Brass
8	Packing Gland	PTFE
9	O-Ring	EPDM
10	Washer	PTFE
11	Stem	C36000
12	Body	C37700
13	Ball	Local Brass
14	Seat	PTFE
15	Bonnet	C37700

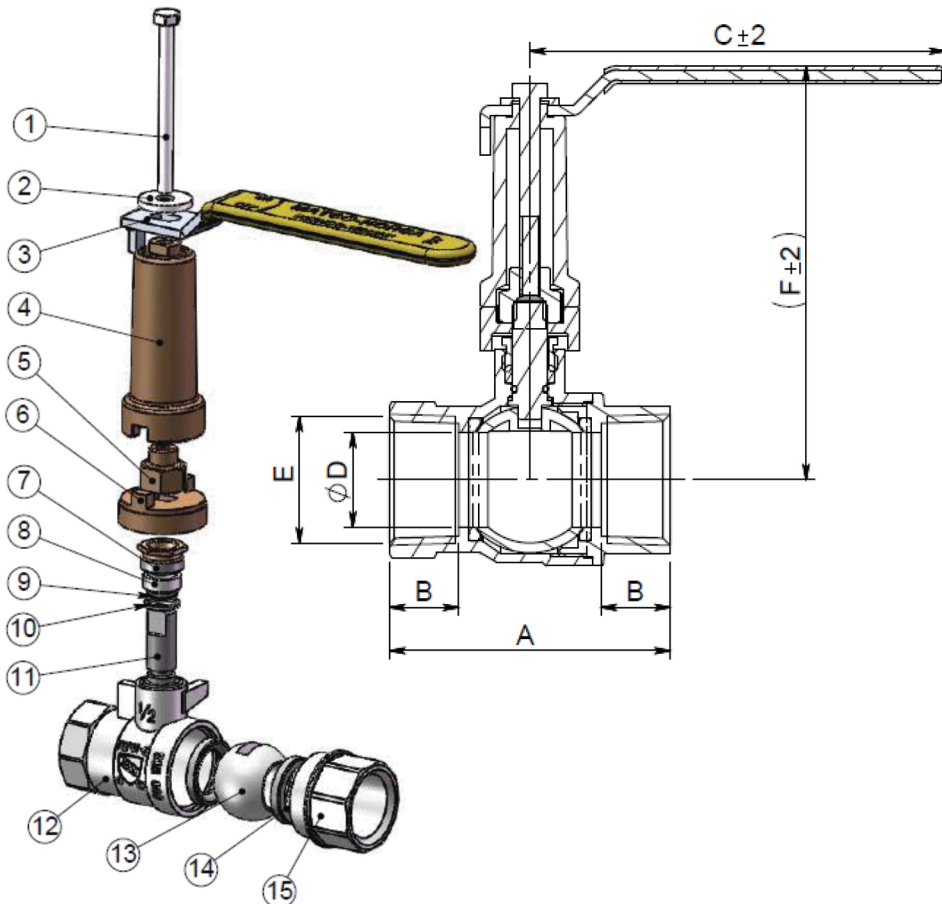

# P759EXT STEM EXTENSION

## Specification Sheet

### FEATURES & BENEFITS

- 759 Ball Valve Stem Extension
- Fits IPS & SWT Standard Valve
- 1" Height Increased 2.17 in.
- 2" Height Increased 2.22 in.
- Does Not Fit the 759 Press Ball Valves



### DIMENSIONS

Part #	Size	A	B	C	D	E	F
P759EXT05	1"	2.80	0.69	4.14	0.95	11.5 NPT	4.14
P759EXT08	2"	4.20	0.75	7.09	1.95	11.5 NPT	5.44

### MATERIAL SPECIFICATIONS

No.	Part	Material
1	Screw	Steel
2	Washer	Local Brass
3	Handle	Steel
4	Heightened Stem Part 1	Local Brass
5	Hex-nut	Local Brass
6	Heightened Stem Part 2	Local Brass
7	Packing Nut	Local Brass
8	Packing Gland	PTFE
9	O-Ring	EPDM
10	Washer	PTFE
11	Stem	C36000
12	Body	C37700
13	Ball	Local Brass
14	Seat	PTFE
15	Bonnet	C37700

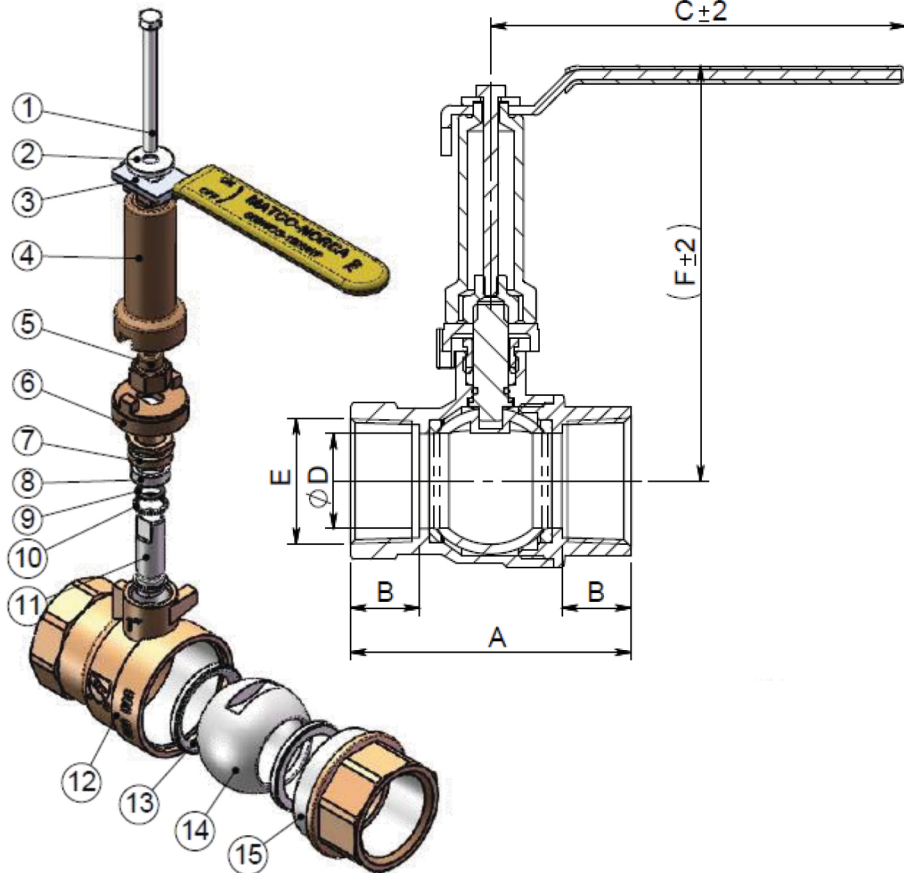

**MATCO  
NORCA**

# P759EXT\_LF STEM EXTENSION

## Specification Sheet

### FEATURES & BENEFITS

- 759 Ball Valve Stem Extension
- Fits IPS & SWT Lead Free Valve
- 1" Height Increased 2.17 in.
- 1-1/4"-2" Height Increased 2.22 in.
- Does Not Fit the 759 Press Ball Valves

### DIMENSIONS

Part #	Size	A	B	C	D	E	F
P759EXT03LF	1/2"	2.05	0.55	3.07	0.51	14 NPT	3.70
P759EXT04LF	3/4"	2.30	0.57	4.14	0.71	14 NPT	3.95
P759EXT05LF	1"	2.80	0.69	4.14	0.95	11.5 NPT	4.14
P759EXT067LF	1-1/4"	3.15	0.69	4.93	1.20	11.5 NPT	4.72
P759EXT067LF	1-1/2"	3.51	0.71	4.93	1.46	11.5 NPT	4.89
P759EXT08LF	2"	4.20	0.75	7.09	1.95	11.5 NPT	5.44



### MATERIAL SPECIFICATIONS

No.	Part	Material
1	Screw	Steel
2	Washer	Local Brass
3	Handle	Steel
4	Heightened Stem Part 1	Local Brass
5	Hex-nut	Local Brass
6	Heightened Stem Part 2	Local Brass
7	Packing Nut	Local Brass
8	Packing Gland	PTFE
9	O-Ring	EPDM
10	Washer	PTFE
11	Stem	1/2-1: C46500 1-1/4-2: Local Brass
12	Body	C37700
13	Ball	1/2-1: C46500 1-1/4-2: AISI 304
14	Seat	PTFE
15	Bonnet	C37700

