

CVC UL Cast Iron Check Valve • Spec Sheet



FEATURES & BENEFITS

- Check Valve-Wafer Style Body
- 175 PSI
- Working Temp -10°C to 82°C
- Spring Loaded Double Disc
- Fusion Bonded Epoxy Coated
Conforming to AWWA C550
- UL Listed
- Sizes 4" - 8"

Note:

- The extremely short face to face dimension and compact design of this valve allow installation and service in tight spaces.
- Spring assisted for better dynamic behavior.
- Soft seated for perfect tightness even at low differential pressure.

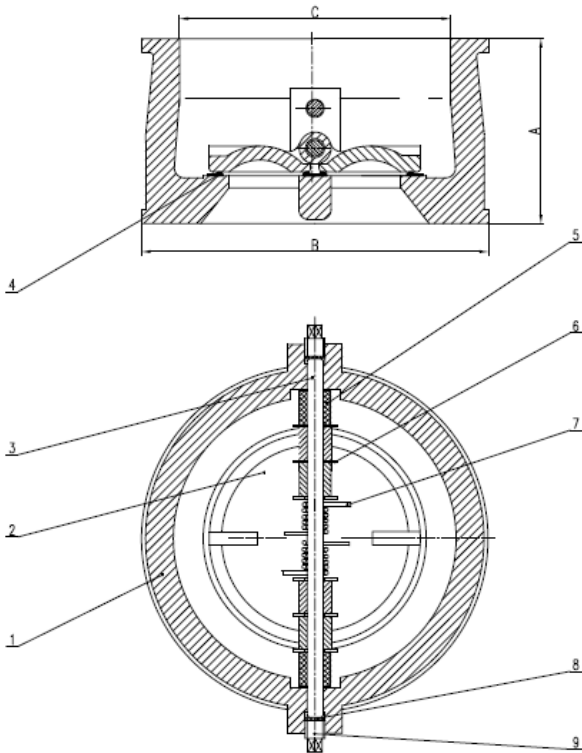

DIMENSIONS

Part #	Size	A	B	C	Weight (lbs)
CVC-4UL	4"	3-11/16	6-3/4	5-3/8	18.5
CVC-6UL	6"	4-1/8	8-11/16	7	29.7
CVC-8UL	8"	4-3/4	11	9-1/16	50.6

MATERIAL SPECIFICATIONS

No.	Part	Material
1	Body	Cast Iron ASTM A126-B
2	Disc	Stainless Steel ASTM CF8
3	Hing & Stop Pin	Stainless Steel AISI 416
4	Seat	EPDM
5	Washer	PTFE
6	Spacer	PTFE
7	Spring	Stainless Steel AISI 304
8	Gasket	PTFE
9	Pin Retainer	Stainless Steel ASTM CF8

 **MATCO-NORCA**
Global sourcing. National compliance. Local service.

CALIFORNIA 5595 Fresca Dr., La Palma CA 90623
TEXAS 1150 Silber Rd., Houston TX 77055
ILLINOIS 278 Windy Point Dr., Glendale Heights, IL 60139
GEORGIA 113 Industrial Blvd., Americus, Georgia 31709
NEW YORK PO Box 27, Rt.22, Brewster NY 10509
 WEB: www.matco-norca.com

• Phone: 866-532-8306 • Fax: 866-532-8307
 • Phone: 800-935-5456 • Fax: 713-680-2999
 • Phone: 844-412-5068 • Fax: 800-640-2252
 • Phone: 800-433-7526 • Fax: 800-533-5134
 • Phone: 800-431-2082 • Fax: 845-278-9056
 EMAIL: mail@matco-norca.com