

DIRECT MOUNT BALL VALVE PACKAGE DIMENSIONS

Use this document to develop envelope dimensions for direct mount ball valve packages.
 Dimensions are MAX to allow for tolerances and slight variations that may be necessary for actuator mounting.
 All dimensions are in inches.

MZ99 Ball Valve Series (in.)

SIZE	ØI.D.	A	B
1/2"	0.63	3.39	1.73
3/4"	0.79	3.90	2.13
1"	0.98	4.61	2.31
1-1/2"	1.50	5.83	3.31
2"	1.97	6.69	3.62

EZ-TORK Actuator Dimensions (in.)

MODEL	Actuator Code DA SR	L (Length)	W** (Width)	C (Height)
50	BNB -	6.06	2.78	2.76
65	CNB CDB -	7.44	3.52	3.50
75	DNB DAB DDB	8.27	4.04	3.94
85	ENB EAB EDB	9.02	4.43	4.45
95	- FAB -	10.39	4.96	4.84
110	- GDB -	10.47	5.45	5.35
125	- HAB -	13.27	6.18	6.34

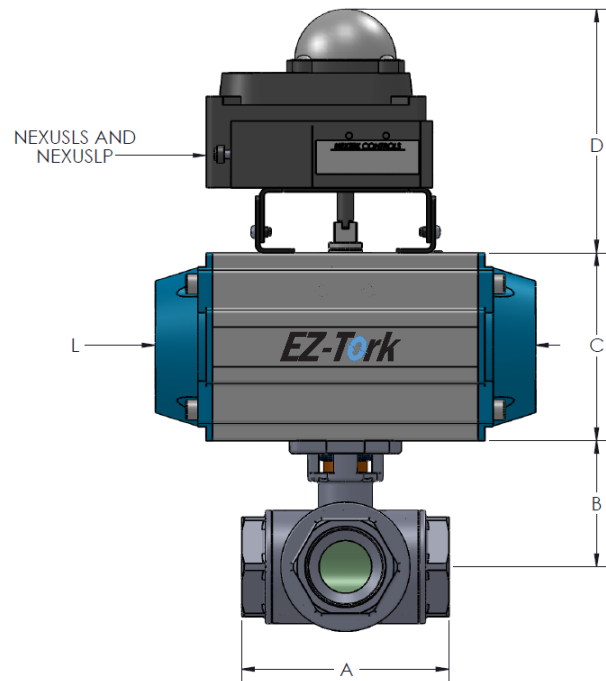
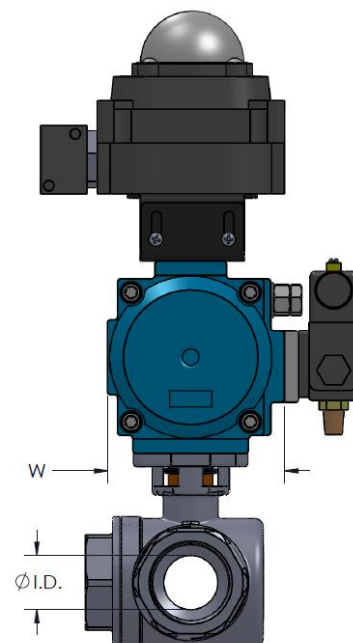
Side View:

Front View:

Options & Accessories

The following tables contain dimensions for top and side mounted accessories, represented by dimension "D" (Height) and "W" (Width).

**D and W are defined at its maximum dimension.

Limit Switch	D**	Rating
SVF	(in.)	
NEXUSLS	5.0	NEMA 4
NEXUSLP	7.0	NEMA 4

Pilot Valve	Add to "W"
SVF	(in.)
Series PV	2.0