

**DIRECT MOUNT BALL VALVE PACKAGE DIMENSIONS**

Use this document to develop envelope dimensions for direct mount ball valve packages.  
 Dimensions are MAX to allow for tolerances and slight variations that may be necessary for actuator mounting.  
 All dimensions are in inches.

**BZ99 Ball Valve Series (in.)**

SIZE	ØI.D.	A1 (SE END)	A2 (TE END)	B
1/2"	0.59	2.91	2.60	1.57
3/4"	0.81	3.19	3.07	1.85
1"	0.98	3.74	3.62	2.05
1-1/2"	1.50	4.37	4.53	2.83
2"	1.97	5.20	5.71	3.15

**EZ-TORK Actuator Dimensions (in.)**

MODEL	Actuator Code DA	Code SR	L (Length)	W** (Width)	C (Height)
32	ANB	-	4.33	1.85	1.97
50	BNB	BAB	6.06	2.78	2.76
		BDB			
65	CNB	CAB	7.44	3.52	3.50
		CDB			
75	DNB	DAB	8.27	4.04	3.94
		-			
85	ENB	EAB	9.02	4.43	4.45
		EDB			
95	FNB	FAB	10.39	4.96	4.84
		-			

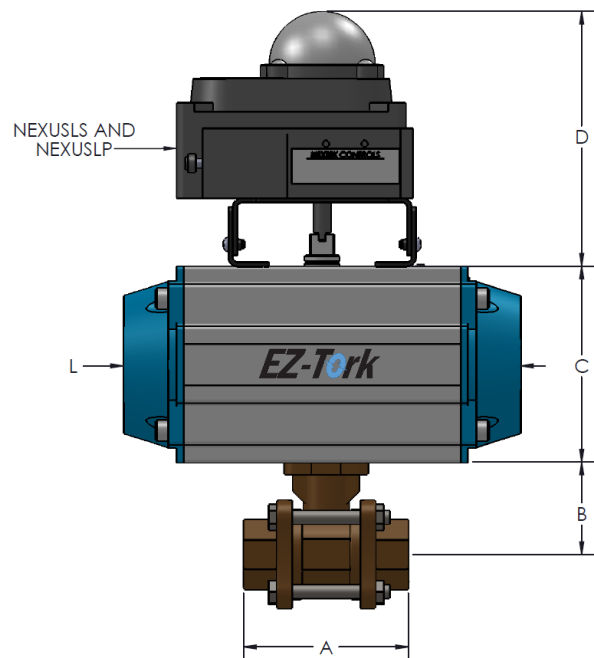
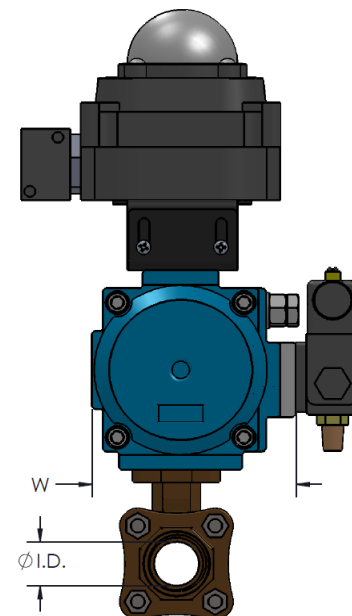
**Side View:**

**Front View:**

**Options & Accessories**

The following tables contain dimensions for top and side mounted accessories, represented by dimension "D" (Height) and "W" (Width).

\*\*D and W are defined at its maximum dimension.

Limit Switch	D**	Rating
SVF	(in.)	
NEXUSLS	5.0	NEMA 4
NEXUSLP	7.0	NEMA 4

Pilot Valve	Add to "W"
SVF	(in.)
Series PV	2.0