

730 Quick Opening Gate Valve • Spec Sheet

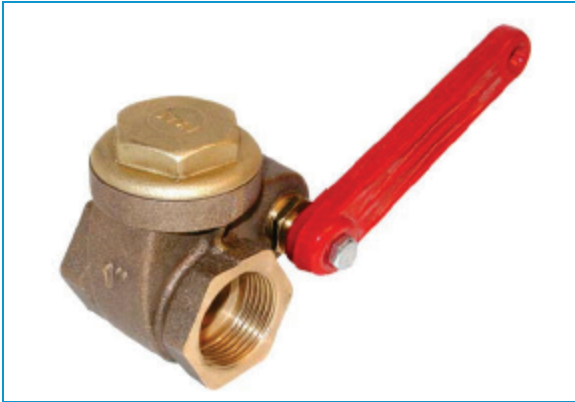

FEATURES & BENEFITS

- Quick Action Gate Valve
- 200 WOG, 125 SWP
- Heavy Cast Bronze Body
- Lever Handle
- Split Wedge Disc
- IPS Only
- Threaded Ends Conform to ANSI B1.20.1
- Sizes: 1/2" - 4"

Application: Heating Plants, Water, Compressed Air, Hygienic Sanitary, Agricultural Distribution for Non Corrosive Fluids

DIMENSIONS

Part #	Size (Dn)	Ø	L	B	F	CH	A
730T03	1/2"	0.59	1.81	1.58	0.51	1.06	3.15
730T04	3/4"	0.79	2.01	1.89	0.55	1.38	3.94
730T05	1"	0.99	2.25	2.17	0.63	1.62	3.94
730T06	1-1/4"	1.26	2.40	2.44	0.67	2.01	4.73
730T07	1-1/2"	1.46	2.64	2.68	0.75	2.25	5.36
730T08	2"	1.85	3.03	3.19	0.79	2.72	6.50
730T09	2-1/2"	2.29	3.66	4.26	0.95	3.43	8.08
730T10	3"	2.84	3.98	4.77	1.06	3.90	8.08
730T11	4"	3.62	4.53	5.83	1.14	4.93	10.05

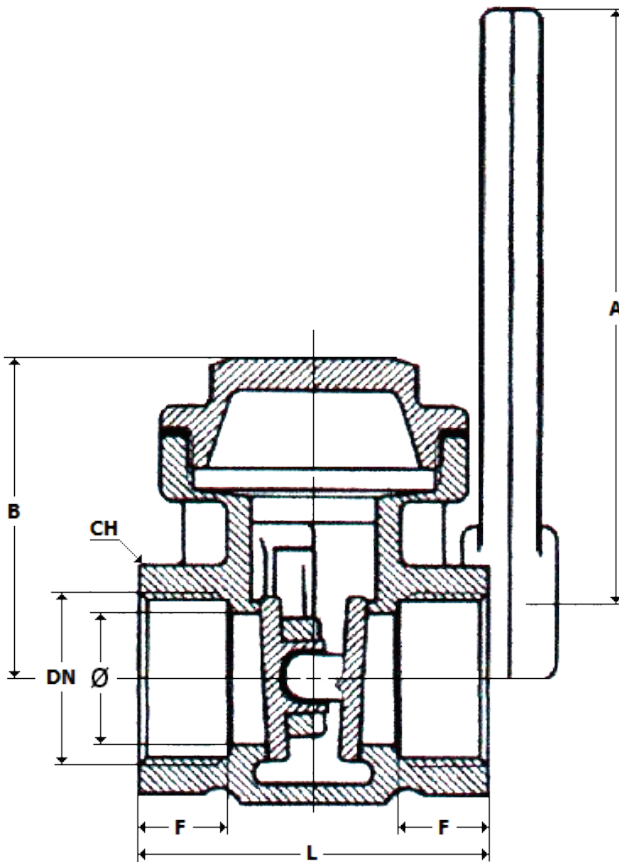

MATERIAL SPECIFICATIONS

Part	Material
Body	Bronze UNI EN1982
Plug	Brass UNI EN12165
M&F Disk	Brass UNI EN12165
Plug Gasket	PTFE G416
Gland Gasket	Fibre AF/15/MA S
Packing Gland & Stem	Brass UNI EN1264
Stem Stopping Ring	Brass UNI EN1264
Small Lever	Brass UNI EN12165
Operating Lever	Aluminium Alloy EN AB-46100
Screw	Carbon Steel UNI 5739

 **MATCO-NORCA**
Global sourcing. National compliance. Local service.

CALIFORNIA 5593 Fresca Dr., La Palma CA 90623 • Toll Free: 866-532-8306 • Fax: 866-532-8307
TEXAS 1150 Silber Rd., Houston TX 77055 • Toll Free: 800-935-5456 • Fax: 713-680-2999
NEW YORK PO Box 27, Rt. 22, Brewster NY 10509 • Toll Free: 800-431-2082 • Fax: 845-278-9056
 WEB: www.matco-norca.com EMAIL: mail@matco-norca.com