

# 530 Bronze Swing Check Valve

## Specification Sheet

### FEATURES & BENEFITS

- Bronze Swing Check Valve
- 300 WOG Non-Shock
- 150 WSP
- Horizontal Pattern
- Threaded Cap
- Threaded Ends Conform to ASME B1.20.1
- Valves Comply with MSS SP-80

**Applications:** Commercial, Light Industrial for Water, Oil, Gas and Steam



### DIMENSIONS

Part #	Size	H	L
530T02	3/8"	1.42	2.09
530T03	1/2"	1.42	2.09
530T04	3/4"	1.56	2.36
530T05	1"	1.77	2.62
530T06	1-1/4"	2.07	3.19
530T07	1-1/2"	2.17	3.55
530T08	2"	2.74	4.22
530T09	2-1/2"	3.09	5.14
530T10	3"	3.80	5.77
530T11	4"	4.26	6.84

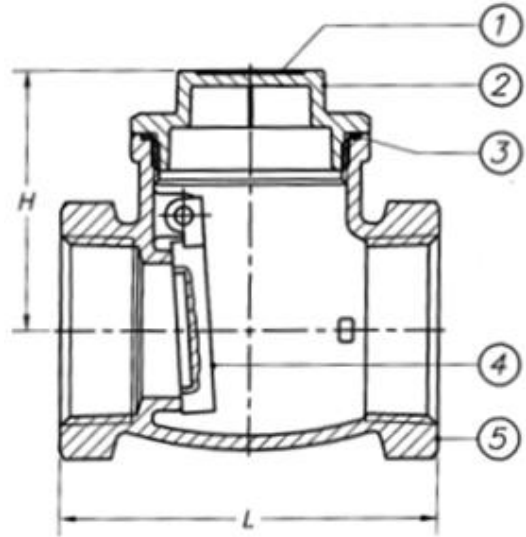

### MATERIAL SPECIFICATIONS

No.	Part	Material
1	Name Plate	Aluminum A1100
2	Bonnet	Bronze C83600
3	Packing	Fibre
4	Disc	Bronze C83600
5	Body	Bronze C83600
6	Bolt	Brass C37700
7	Pin	Brass C46400

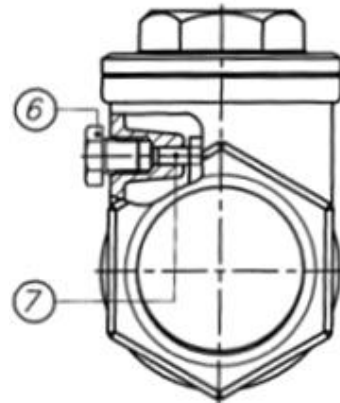

**MATCO**  
**NORCA**