

# 521NLF Swing Check Valve • Spec Sheet



## FEATURES & BENEFITS

- Lead Free Brass\*
- 200 WOG
- Swing Type
- BUNA-N Seat
- Threaded Ends Comply w/ ANSI B2.1 1/2" - 2"
- Valves Tested in Accordance w/ MSS-SP-82
- ISO-9002
- Sizes 1/2" - 2"

## DIMENSIONS

Part #	Size	H	L
521N03LF	1/2"	1.42	2.09
521N04LF	3/4"	1.56	2.36
521N05LF	1"	1.77	2.62
521N06LF	1-1/4"	2.07	3.19
521N07LF	1-1/2"	2.17	3.55
521N08LF	2"	2.74	4.22

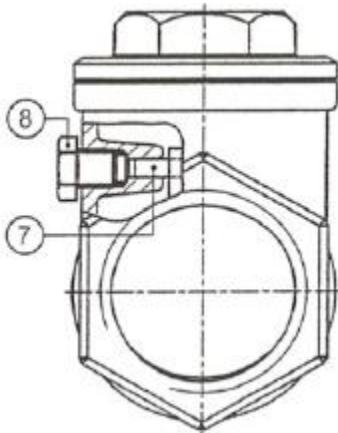
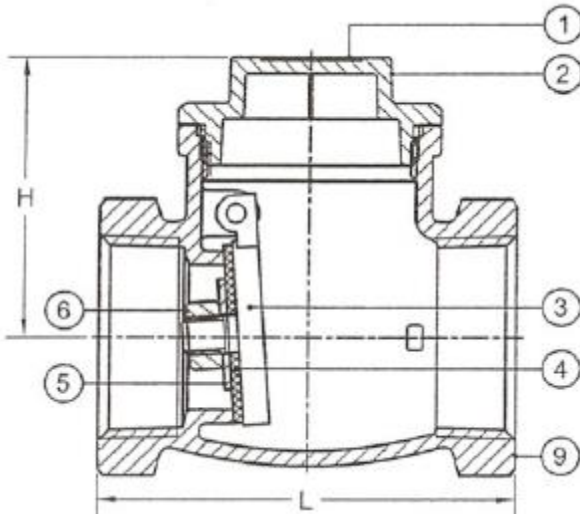

## MATERIAL SPECIFICATIONS

No.	Parts	Material
1	Name Plate	Aluminum A1100
2	Cap	Brass C89550
3	Disc Holder	Brass C89550
4	Seat Packing	BUNA-N
5	Washer	Brass C89550
6	Nut	Brass B19 C26000
7	Pin	Brass B19 C26000
8	Lock Bolt	Brass C89550
9	Body	Brass C89550

\* This product complies with 0.25% weighted average lead content on wetted surfaces in accordance with CA AB1953.

