

521N Brass Check Valve • Spec Sheet



FEATURES & BENEFITS

- 200 WOG
- Cast Brass Body
- Swing Type
- Threaded Ends Comply with ANSI B2.1 3/8" - 4"
- Valves are Tested in Accordance w/MSS-SP-82

DIMENSIONS

Size	H	L	Weight (lbs)
3/8"	1.42	2.09	.39
1/2"	1.42	2.09	.42
3/4"	1.56	2.36	.55
1"	1.77	2.62	.75
1-1/4"	2.07	3.19	1.34
1-1/2"	2.17	3.55	1.69
2"	2.74	4.22	2.64
2-1/2"	3.09	5.14	4.8
3"	3.80	5.77	6.87
4"	4.26	6.84	11.36

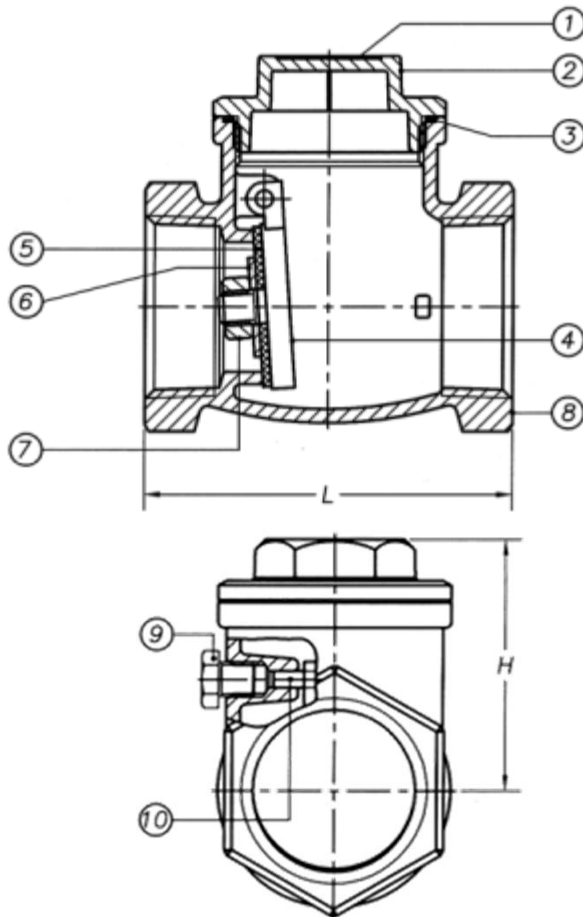

MATERIAL SPECIFICATIONS

No.	Part	Material
1	Name Plate	Aluminum A1100
2	Cap	Brass B584 C85710
3	Packing	Fibre "H"
4	Disc Holder	Brass B584 C85710
5	Seat Packing	BUNA-N
6	Washer	Brass B584 C85710
7	Seat Nut	Brass B124 C37700
8	Body	Brass B584 C85710
9	Bolt	Brass B16 C36000
10	Pin	Brass B124 C37700

MATCO-NORCA
Global sourcing. National compliance. Local service.

CALIFORNIA 5593 Fresca Dr., La Palma CA 90623 • Toll Free: 866-532-8306 • Fax: 866-532-8307
TEXAS 1150 Silber Rd., Houston TX 77055 • Toll Free: 800-935-5456 • Fax: 713-680-2999
NEW YORK PO Box 27, Rt. 22, Brewster NY 10509 • Toll Free: 800-431-2082 • Fax: 845-278-9056
 WEB: www.matco-norca.com EMAIL: mail@matco-norca.com