

519 BRASS GATE VALVE



- ❖ Full Port ❖ Cast Brass ❖ Non Rising Stem
 - ❖ Adjustable Packing Gland ❖ Compression Ends
- 200 PSI NON-SHOCK WOG 125 PSI SWP**

Applications: Commercial, Residential, Light Industrial for Steam, Water, Oil, Gas

Valves are Tested in Accordance with MSS-SP-82
 Compression Ends Suitable for Use with Copper Tubing



MATERIAL SPECIFICATIONS

NO.	PART	MATERIAL	ASTM SPEC
1	Wheel Nut	Plated Steel	Commercial
2	Name Plate	Aluminum	Commercial
3	Hand Wheel	Cast Iron	Commercial
4	Packing Nut	Brass	B16 GR3600
5	Gland Packing	Graphite	Non Asbestos
6	Bonnet	Cast Brass	B584 GRC85700
7	Lock Nut	Brass	B16 GR3600
8	Stem	Brass	B16 GR3600
9	Disc	Cast Brass	B584 GRC85700
10	Body	Cast Brass	B584 GRC85700
11	Compression Ring	Brass Tube	B16 GR3600
12	Compression Nut	Brass	B584 GRC85700

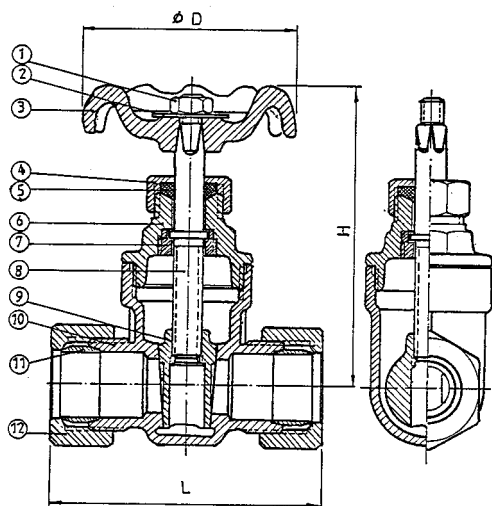

DIMENSIONS

SIZE (in.)	L	H	W	WT. (lbs.)
1/2"	2.62	2.91	2.00	.70
3/4"	2.89	3.22	2.28	.94
1"	3.34	3.89	2.55	1.36

Product Specs Sheet



BREWSTER: TEL:800-431-2082 FAX: 800-640-2252 HOUSTON: TEL: 800-935-5456 FAX:800-683-4247

PREVIOUS

Click The Product Name Below To Return To That Index
 BRASS & BRONZE VALVES CAST IRON VALVES FAUCETS

NEXT