

# 517 BRASS GATE VALVE



- ❖ Full Port
- ❖ Cast Brass
- ❖ Non Rising Stem
- ❖ Drainable Body
- ❖ Adjustable Packing Gland
- ❖ Threaded or Solder Ends

**200 PSI NON-SHOCK WOG    125 PSI SWP**

Applications: Commercial, Residential, Light Industrial for Water, Oil, Gas

Threaded Ends Conform to ANSI Standards B2.1  
 Solder Ends Conform to ANSI Standards B16.18  
 Valves are Tested in Accordance with MSS-SP-82

## DIMENSIONS & WEIGHTS

| SIZE<br>(inch) | L    | P    | H    | D    | Wts. (lbs.) |       |
|----------------|------|------|------|------|-------------|-------|
|                |      |      |      |      | IPS         | C x C |
| 1/2"           | 1.71 | 1.69 | 2.91 | 2.00 | .62         | .50   |
| 3/4"           | 1.81 | 2.32 | 3.31 | 2.28 | .84         | .77   |
| 1"             | 2.12 | 2.71 | 3.90 | 2.55 | 1.22        | 1.12  |



## MATERIAL SPECIFICATIONS

| NO. | PART             | MATERIAL     | ASTM SPEC     |
|-----|------------------|--------------|---------------|
| 1   | Wheel Nut        | Plated Steel | Commercial    |
| 2   | Name Plate       | Aluminum     | Commercial    |
| 3   | Hand Wheel       | Cast Iron    | Commercial    |
| 4   | Packing Nut      | Brass        | B16 GR3600    |
| 5   | Gland Packing    | Graphite     | Non Asbestos  |
| 6   | Bonnet           | Cast Brass   | B584 GRC85700 |
| 7   | Stem             | Brass        | B16 GR3600    |
| 8   | Lock Nut         | Brass        | B16 GR3600    |
| 9   | Disc             | Cast Brass   | B584 GRC85700 |
| 10  | Body             | Cast Brass   | B584 GRC85700 |
| 11  | Drain Cap Washer | BUNA-N       | Commercial    |
| 12  | Drain Cap        | Brass        | B16 GR3600    |

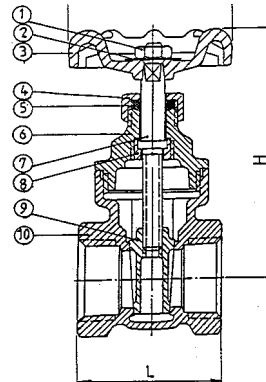
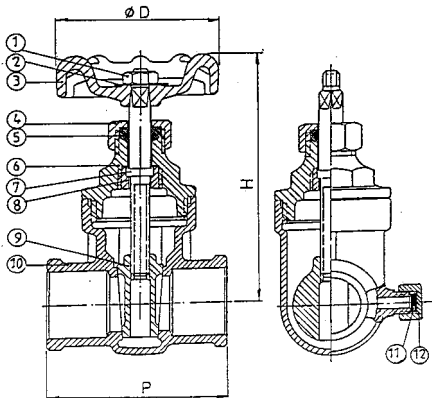

Product Spec Sheet



BREWSTER: TEL: 800-431-2082 FAX: 800-640-2252    HOUSTON: TEL: 800-935-5456 FAX: 800-683-4247