

# Series 430CSF-8 Gate Valve

Sizes 2" ~ 12"  
Trim 8



## SERIES 430CSF DESIGN FEATURES

- ✓ Cast Steel ASTM A216-WCB
- ✓ Class 300# flanged ends
- ✓ Maximum Pressure - 740 psi
- ✓ Maximum Temperature - 1000F
- ✓ Outside screw and yoke
- ✓ API 600 compliant
- ✓ Standard NACE MRO175
- ✓ Trim 8

## MATERIALS OF CONSTRUCTION

No.	Part	Material
1	Body	ASTN A216 WCB
2	Seat	ASTM A105+STL
3	Wedge	ASTM A216 WCB+13CR
4	Stem	ASTM A182 F6A
5	Gasket	304+FLEXIBLE GRAPHITE
6	Bonnet Bolt	ASTM A193 B7M
7	Nut	ASTM A194 2HM
8	Bonnet	ASTM A216 WCB
9	Back Seat	ASTM A76 410
10	Packing	FLEXIBLE GRAPHITE
11	Gland	ASTM A276 410
12	Gland Flange	ASTM A216 WCB
13	Pin	CS
14	Eyebolt	ASTM A193 B7M
15	Nut	ASTM A194 2HM
16	Stem Nut	ASTM A536 FCD45
17	Clamp Nut	ASTM A29 1025
18	Handwheel	ASTM A47 32510
19	Lock Nut	ASTM A29 1035
20	Screw Cap	COPPER ALLOY
21	Rivet	SS
22	Name Plate	SS
23	Yoke Bolt	ASTM A193 B7M
24	Nut	ASTM A194 2HM
25	Yoke	ASTM A216 WCB

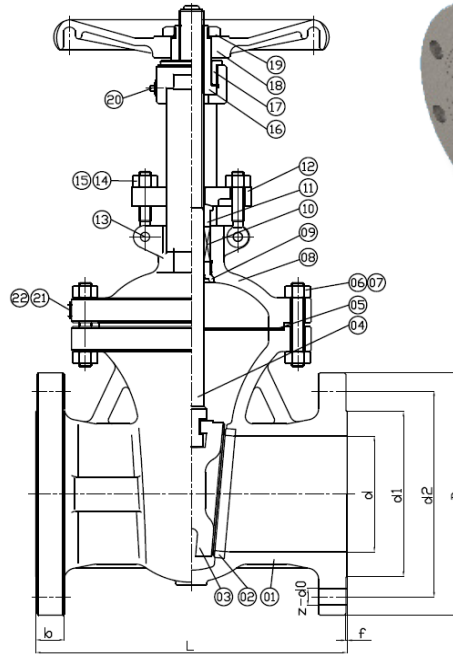
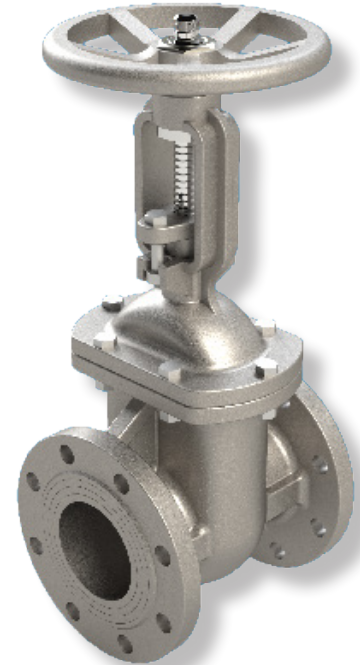

PART NUMBER & DIMENSIONS									
Part Number	Size	d	L	D	d1	d2	b	f	n-Ød
430CSF08-8	2"	2.00	8.5	6.5	3.63	5.0	0.89	0.08	8 - 5/8
430CSF09-8	2-1/2"	2.51	9.5	7.5	4.13	5.9	1.02	0.08	8 - 3/4
430CSF10-8	3"	2.99	11.1	8.3	5.00	6.6	1.14	0.08	8 - 3/4
430CSF11-8	4"	4.01	12.0	10.0	6.19	7.9	1.27	0.08	8 - 3/4
430CSF12-8	5"	5.00	15.0	11.0	7.31	9.3	1.39	0.08	8 - 3/4
430CSF13-8	6"	5.98	15.6	12.6	8.5	10.6	1.46	0.08	12 - 3/4
430CSF14-8	8"	7.99	16.5	15.0	10.6	13.0	1.64	0.08	12 - 7/8
430CSF15-8	10"	10.00	18.0	17.5	12.7	15.3	1.89	0.08	16 - 1
430CSF16-8	12"	12.00	19.8	20.5	15.0	17.7	2.02	0.08	16 - 1-1/8

What do you need today?™

