

# 225RT DI Push-On x Push-On Valve

## Specification Sheet

### FEATURES & BENEFITS

- Ductile Iron Gate Valve
- Push-On x Push-On (C900/DI Pipe)
- Resilient Wedge
- Non Rising Stem
- AWWA C515-15
- AWWA C550 Epoxy
- 300 PSI
- Temp Range of 140°F - 180°F
- UL Listed / FM Approved
- NSF-61 / NSF-372 verified by UL Water Quality
- Can Be Fitted With Post Indicator Plate

### MATERIAL SPECIFICATIONS

No.	Part	Material	ASTM Spec.
1	Body	Ductile Iron	A536-65-45-12
2	Wedge	Ductile Iron EPDM Encapsulated	A536-65-45-12
3	Stem Nut	Bronze	ASTM C95200
4	Stem	Stainless Steel	ANSI 304
5	Gasket	Rubber	EPDM
6	Bolt	Stainless Steel	SS304
7	Bonnet	Ductile Iron	A536-65-45-12
8	O-Ring	Rubber	NBR
9	Thrust Collar	Bronze	ASTM C95200
10	O-Ring	Rubber	NBR
11	Gland	Ductile Iron	A536-65-45-12
12	O-Rings	Rubber	NBR
13	Dust Ring	Rubber	NBR
14	Operating Nut (Optional)	Ductile Iron	A536-65-45-12
15	Bolts	Stainless Steel	SS304
16	Washer	Stainless Steel	SS304
17	Handwheel (Optional)	Ductile Iron	A536-65-45-12
18	Bolts	Stainless Steel	SS304

### DIMENSIONS

Part #	Size	L	H	D	A
225RT11	4"	14	16	10.0	6.0
225RT13	6"	15	19	12.0	7.0
225RT14	8"	18	23	14.0	9.0
225RT15	10"	18.5	26	17.5	9.5
225RT16	12"	18.5	31	17.5	8.5

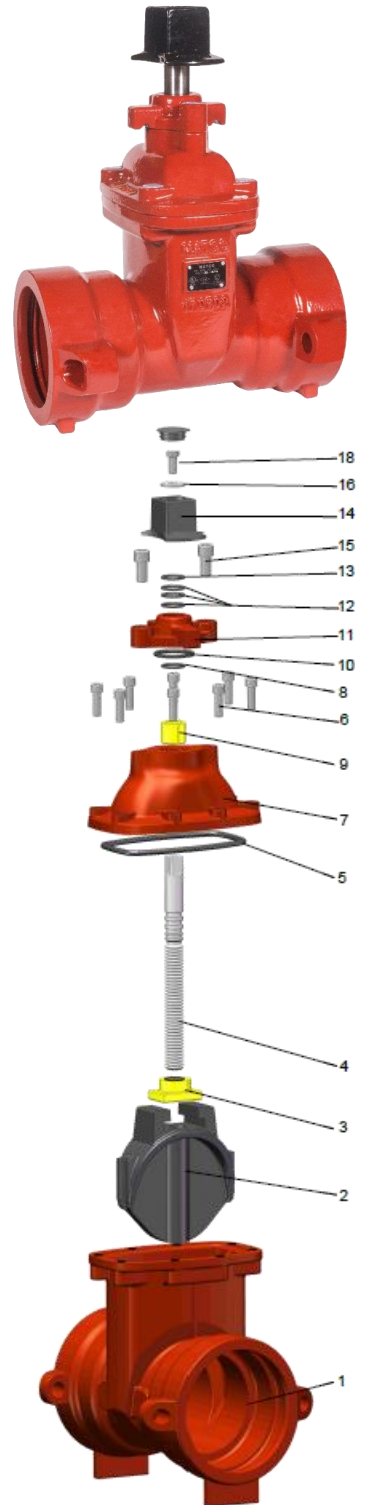
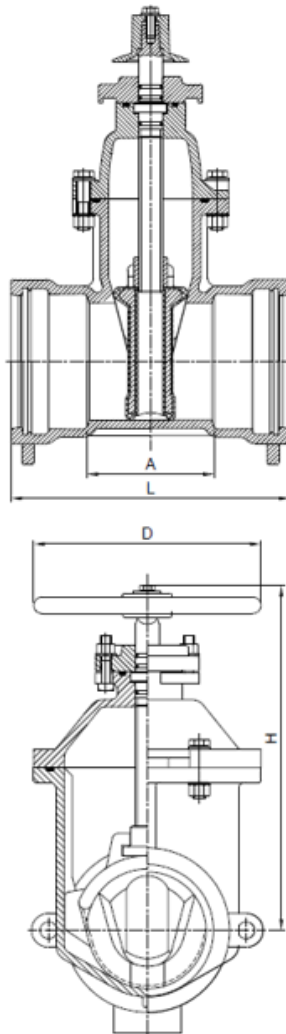

**MATCO**  
**NORCA**