

225FP DI Flanged x Push-On Valve

Specification Sheet

FEATURES & BENEFITS

- Ductile Iron Gate Valve
- Flanged x Push-On (C900/DI Pipe)
- Resilient Wedge
- Non Rising Stem
- AWWA C515-15
- AWWA C550 Epoxy
- 300 PSI
- Temp Range of 140°F - 180°F
- UL Listed / FM Approved
- NSF-61 / NSF-372 verified by UL Water Quality
- Can Be Fitted With Post Indicator Plate

MATERIAL SPECIFICATIONS

No.	Part	Material	ASTM Spec.
1	Body	Ductile Iron	A536-65-45-12
2	Wedge	Ductile Iron EPDM Encapsulated	A536-65-45-12
3	Stem Nut	Bronze	ASTM C95200
4	Stem	Stainless Steel	ANSI 304
5	Gasket	Rubber	EPDM
6	Bolt	Stainless Steel	SS304
7	Bonnet	Ductile Iron	A536-65-45-12
8	O-Ring	Rubber	NBR
9	Thrust Collar	Bronze	ASTM C95200
10	O-Ring	Rubber	NBR
11	Gland	Ductile Iron	A536-65-45-12
12	O-Rings	Rubber	NBR
13	Dust Ring	Rubber	NBR
14	Operating Nut (Optional)	Ductile Iron	A536-65-45-12
15	Bolts	Stainless Steel	SS304
16	Washer	Stainless Steel	SS304
17	Handwheel (Optional)	Ductile Iron	A536-65-45-12
18	Bolts	Stainless Steel	SS304

DIMENSIONS

Part #	Size	L	H	D	A
225FP11	4"	11.5	16	10.0	7.5
225FP13	6"	12.5	19	12.0	8.5
225FP14	8"	14.5	23	14.0	10.0
225FP15	10"	15.5	26	17.5	11.0
225FP16	12"	16.5	31	17.5	11.5

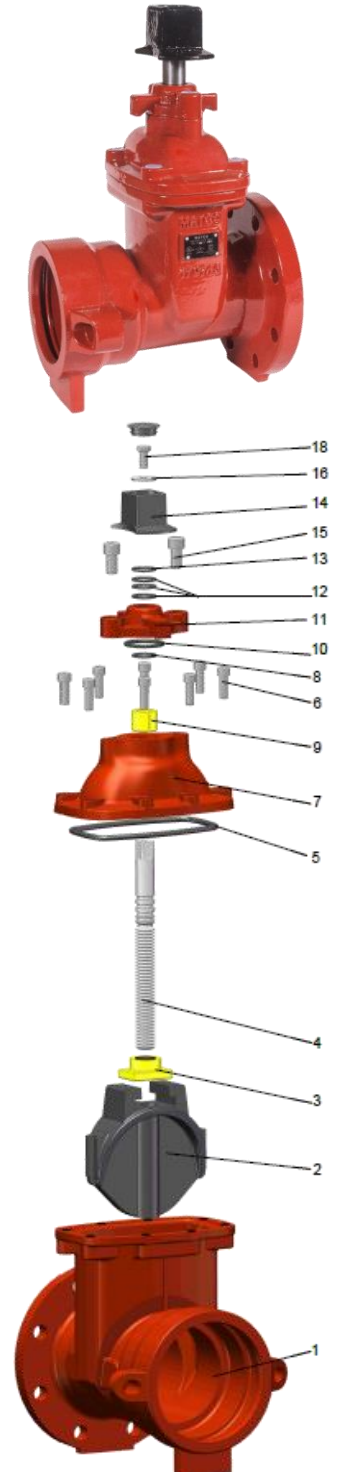
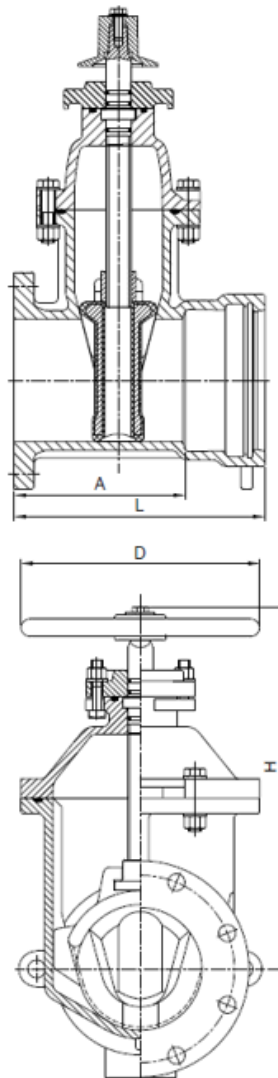

MATCO
NORCA