

205F BOILER DRAINS



- ❖ Full Flow ❖ Brass Body ❖ Angle Spout
- ❖ 3/4" Hose Outlet ❖ With Stuffing Box

125 PSI CWP

Product Spec Sheet

ISO 9001:2000



Pipe Threads Comply With ANSI B2.1
Solder Connections Comply With ANSI B16.18
Hose Threads Comply With ANSI B2.4



205F

205FF

205X

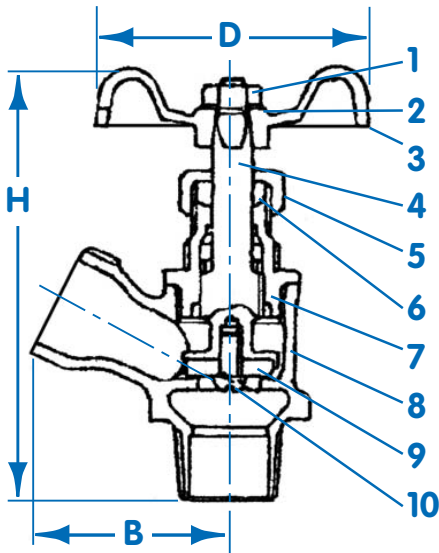

MATERIAL SPECIFICATIONS

NO.	Part	Material	ASTM Designation
1	Wheel Nut	Steel	AISI-1020
2	Name Plate	Aluminum	B209-110
3	Hand Wheel	Cast Iron	A48 Class 35
4	Stem	Cast Brass	B584-C857
5	Packing Nut	Brass Rod	B16-C36000
6	Gland Packing	Graphite	Graphite
7	Bonnet	Cast Brass	B584-C857
8	Body	Cast Brass	B584-C857
9	Seat Packing	Rubber	NBR
10	Seat Packing Screw	Brass	B16-C36000

DIMENSIONS

MODEL/SIZE	B	H	D
205F-MIP			
1/2"	1.58	3.74	2.13
3/4"	1.58	3.86	2.13
205FF - FIP			
1/2"	1.58	3.74	2.13
3/4"	1.58	3.86	2.13
205X - (205F w/Cross Handle)			
1/2"	1.58	3.74	2.13



Brewster, NY
TEL: 800-431-2082
FAX: 800-640-2252

Houston, TX
TEL: 800-935-5456
FAX: 800-683-4247

La Palma, CA
TEL: 866-532-8306
FAX: 866-532-8307

Americus, GA
TEL: 800-433-7526
FAX: 800-533-5134

e-mail: mail@matco-norca.com

www.matco-norca.com