

204LSLF Long Shank Boiler Drain • Spec Sheet



FEATURES & BENEFITS

- Lead Free Brass*
- ISO-9002
- 125 WOG
- Boiler Drain-Less Stuffing Box
- cUPC Approved
- Shank Lock Nut
- 1/2" MIP x 1/2" Solder Inlet

204LS3LF - Long Shank 1/2" MIP with Locknut
204LS3PLF - Long Shank 1/2" MIP with Locknut & Pex Connection

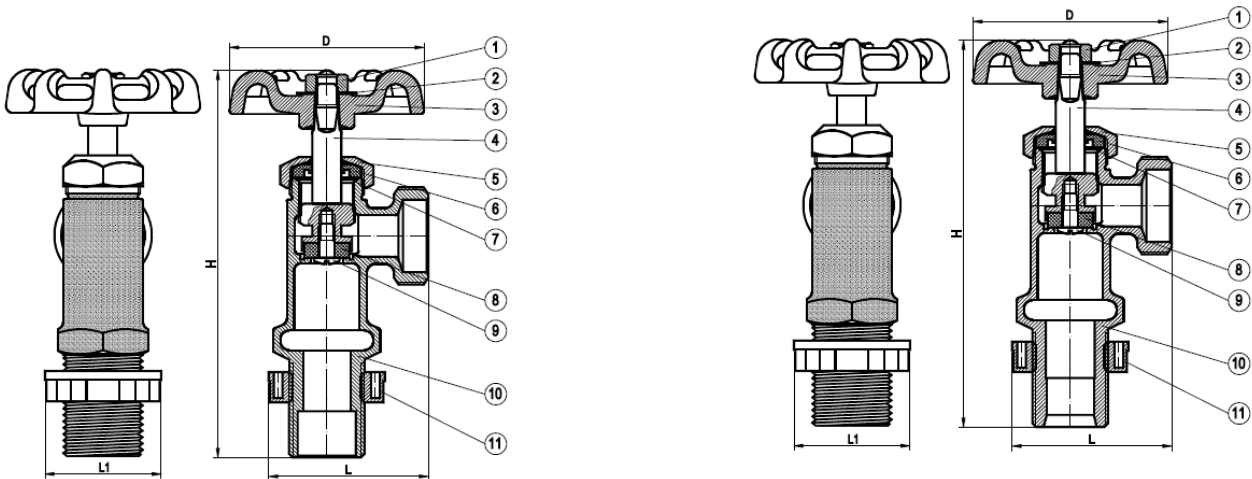

MATERIAL SPECIFICATIONS

DIMENSIONS

No.	Part	Material	No.	Part	Material
1	Wheel Nut	Hot Rolled Wire Rods	7	Washer	Stainless Steel 304
2	Name Plate	Aluminum 1070	8	Seat Packing	SE-719F / SN-719F
3	Hand Wheel	Rod-Carbon Steel SAE 1006	9	Seat Screw	JIS H3260 – C2600W
4	Stem	Brass C46400	10	Body	Brass C46400
5	Bonnet	Brass B124 C37700	11	Lock Nut	POM M90 Polyacetal
6	Packing	SE-719F / SN-719F			

Part #	H	L	L1	D
204LS3LF	4.20	1.73	1.26	2.11
204LS3PLF	4.20	1.73	1.26	2.11

* These product complies with 0.25% weighted average lead content on wetted surfaces in accordance with Safe Water Drinking Act (SDWA) / Federal Public Law No. 111-380.



Global sourcing. National compliance. Local service.

CALIFORNIA 5593 Fresca Dr., La Palma CA 90623 • Toll Free: 866-532-8306 • Fax: 866-532-8307
TEXAS 1150 Silber Rd., Houston TX 77055 • Toll Free: 800-935-5456 • Fax: 713-680-2999
NEW YORK PO Box 27, Rt. 22, Brewster NY 10509 • Toll Free: 800-431-2082 • Fax: 845-278-9056
 WEB: www.matco-norca.com EMAIL: mail@matco-norca.com