

200F Flanged Cast Iron Gate Valve • Spec Sheet



FEATURES & BENEFITS

- Gate Valve-Flanged Ends
- 200 WOG – Not For Steam Service
- Iron Body, Bronze Mounted (IBBM)
- Bolted Bonnet
- Non Rising Stem
- Solid Wedge
- Flanged Ends Conform with ANSI B16.1
- Bituminous Coating
- Sizes 2-1/2" - 10"

DIMENSIONS

Size (DN)	Part #	L	H	D	Approx. WT. LBS.
2-1/2"	200F09	7.49	10.84	7.01	39
3"	200F10	8.00	11.62	7.53	47
4"	200F11	9.06	14.58	9.02	66
6"	200F13	10.52	18.12	10.99	137
8"	200F14	11.50	22.85	13.51	201
10"	200F15	13.00	19.50	16.00	295

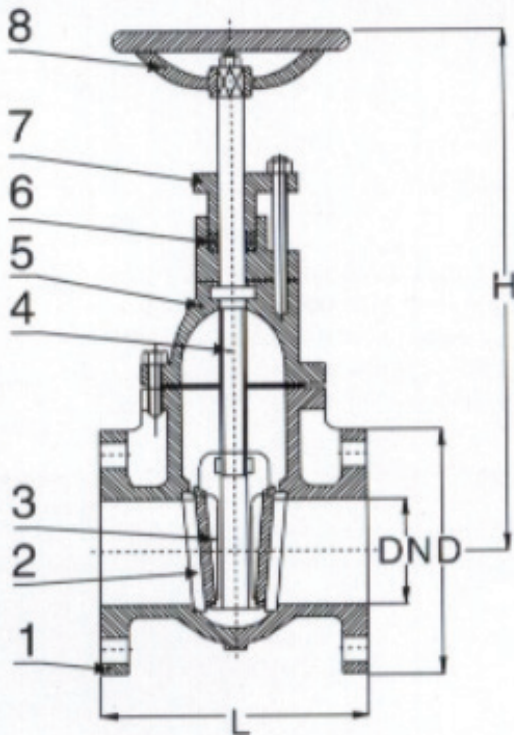

MATERIAL SPECIFICATIONS

No.	Part	Material
1	Body	Cast Iron
2	Seat Ring	Cast Bronze
3	Disc	Cast Iron
4	Stem	Bronze
5	Bonnet	Cast Iron
6	Packing	Graphite
7	Gland	Ductile Iron
8	Handwheel	Cast Iron

 **MATCO-NORCA**
Global sourcing. National compliance. Local service.

CALIFORNIA 5593 Fresca Dr., La Palma CA 90623 • Toll Free: 866-532-8306 • Fax: 866-532-8307
TEXAS 1150 Silber Rd., Houston TX 77055 • Toll Free: 800-935-5456 • Fax: 713-680-2999
NEW YORK PO Box 27, Rt. 22, Brewster NY 10509 • Toll Free: 800-431-2082 • Fax: 845-278-9056
 WEB: www.matco-norca.com EMAIL: mail@matco-norca.com