

115S IRON BODY SWING CHECK VALVE

- ❖ Iron Body, Threaded Ends ❖ Bronze Mounted (IBBM) ❖ Bolted Cover ❖ Full Waterway
- ❖ Class 125 ❖ Suitable For Vertical & Horizontal Installation
- ❖ Internal & External Bituminous Coating

200 PSI NON-SHOCK COLD WOG 125 PSI SATURATED STEAM

Applications: Low pressure Steam, Air, Water and Non-Corrosive Gas or Oil

Conforms to MSS-SP-71

Threaded Ends conform to ANSI/ASME B1.20.1
ISO-9002

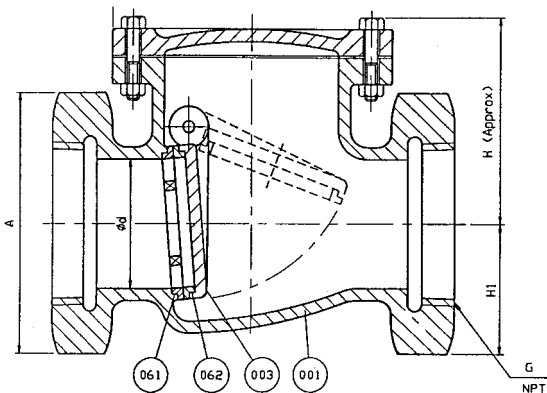
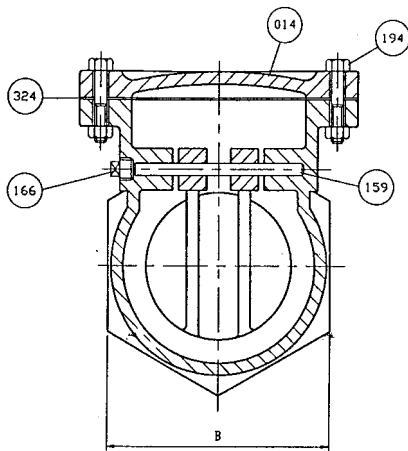

DIMENSIONS & WEIGHTS

SIZE INCH	L	A	B	G	H	HI	APPROX. WT. LBS.
2"	7.00	3.63	3.16	2.00	4.19	1.81	14
2-1/2"	7.50	4.31	3.75	2.50	4.94	2.16	18
3"	9.00	5.00	4.31	3.00	5.94	2.50	27
4"	10.50	7.06	6.13	4.00	6.69	3.53	53
5"	11.25	7.94	6.88	5.00	7.31	3.97	69
6"	12.50	9.44	8.19	6.00	7.69	4.72	99
8"	16.00	11.75	10.25	8.00	9.25	5.88	205

MATERIAL SPECIFICATIONS

NO.	PART	MATERIAL	ASTM DESIGNATION
001	Body	Cast Iron	A 126 Class B
003	Disc	Ductile Iron	A 536 Gr 65-45-12
014	Cover	Cast Iron	A 126 Class B
061	Body Seat Ring	Bronze	B 62
062	Disc Seat Ring	Bronze	B 62
159	Hinge Pin	Stainless Steel	A 276 Type 304
166	Plug	Malleable Iron	A 47
194	Cover Bolt & Nut	Steel	A307 Grade B
324	Cover Gasket	Non Asbestos Sheet	Non-Asbestos

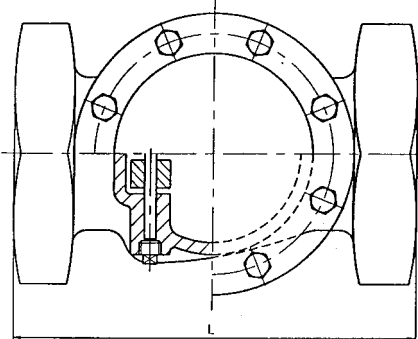

Product Spec Sheet



BREWSTER: TEL:800-431-2082 FAX: 800-640-2252 HOUSTON: TEL: 800-935-5456 FAX:800-683-4247

PREVIOUS

Click The Product Name Below To Return To That Index
BRASS & BRONZE VALVES CAST IRON VALVES FAUCETS

NEXT