

10RT RING TITE GATE VALVE



- ❖ Push-On Connections for IPS OD PVC Pipe
 - ❖ Resilient Wedge
 - ❖ Epoxy Coating - Internal & External
 - ❖ Stainless Steel Stem
- 200 PSI NON-SHOCK WOG MAXIMUM TEMPERATURE 140°F**

Applications: Irrigation, Potable Water, Turf, Golf Course,
Water Distribution Service & Feed Lines, Sewage Disposal

Tested to AWWA C509 Section 5
ASTM A126 Class B
ISO 9002

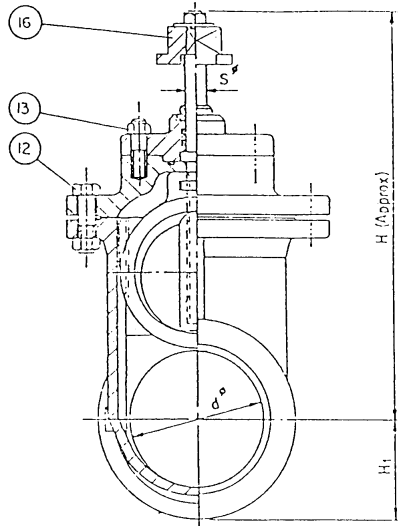

DIMENSIONS & WEIGHTS

SIZE d _ø APP. INCH	L	D _ø	d1	H	H1	S _ø	WT. LBS.
2	10.50	3.50	2.56	7.94	1.75	.63	20
2.5	10.63	4.31	3.06	9.06	2.16	.63	22
3	11.13	5.13	3.63	10.25	2.56	.69	33
4	12.75	5.94	4.69	12.50	2.97	.81	46
6	15.75	8.25	6.75	16.81	4.13	.94	90
8	16.00	10.25	8.81	20.88	5.13	1.00	154

MATERIAL SPECIFICATIONS

NO.	PART	MATERIAL	ASTM DESIGNATION
1	Body	Cast Iron	A 126 Class B
2	Bonnet	Cast Iron	A 126 Class B
3	Disc	Cast Iron Rubber (Buna-N)	A 126 Class B
4	Hand Wheel	Cast Iron	A 126 Class B
5	Stem	Stainless Steel	A 276 Type 304
6	Stuffing Box	Cast Iron	A 126 Class B
7	O-Ring B	Rubber	D 2000 AA 6014
8	O-Ring A	Rubber	D 2000 AA 6014
9	Bonnet Gasket	Rubber	D 2000 AA 6014
10	Stem Nut	Stainless Steel	A 276 Type 304
11	Wiper Ring	Rubber	D 2000 AA 6014
12	Bonnet Bolt & Nut	Steel	A 307 Grade B
13	Stud & Nut	Steel	A 307 Grade B
14	Top Washer	Steel	A 284
15	Top Nut	Steel	A 307 Grade B
16	Operating Nut	Cast Iron	A 126 Class B
17	Pipe Gasket	Rubber	D 2000 AA 6014

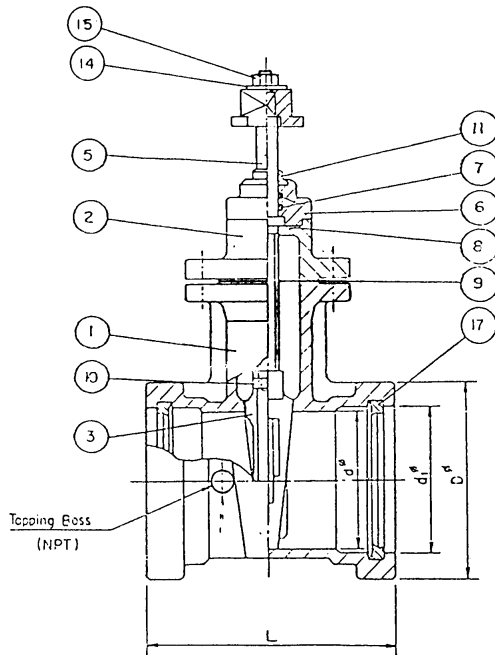

Product Spec Sheet



BREWSTER: TEL: 800-431-2082 FAX: 800-640-2252 HOUSTON: TEL: 800-935-5456 FAX: 800-683-4247