

1.5 GPM Aerator



FEATURES & BENEFITS

- This Product Contains Less Than 0.25% Weighted Average Lead Content On Wetted Surfaces
- Max Flow Rate 1.5 GPM (5.7 L/MIN) At 60 PSI (ASME A112.18.1M/A112.18.1)

AER-15
Chrome Finish

APPROVALS:

Meets or Exceeds The Following:

- * ANSI/ASME A112.18.1M/A112.18.1
- * IAPMO/cUPC



CALIFORNIA:
TEXAS:
NEW YORK:

TEL: 866-532-8306
TEL: 800-935-5456
TEL: 800-431-2082

FAX: 866-532-8307
FAX: 800-683-4247
FAX: 800-640-2252

Visit Our Web Site : www.matco-norca.com

1.5 GPM Aerator

| No. | Name | Part No. |
|-----|-----------------|----------|
| 1 | Seal | A010018N |
| 2 | Flow Restrictor | A553634 |
| 3 | Aerator Shell | A033604 |

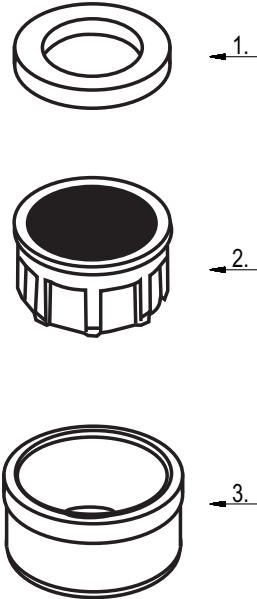

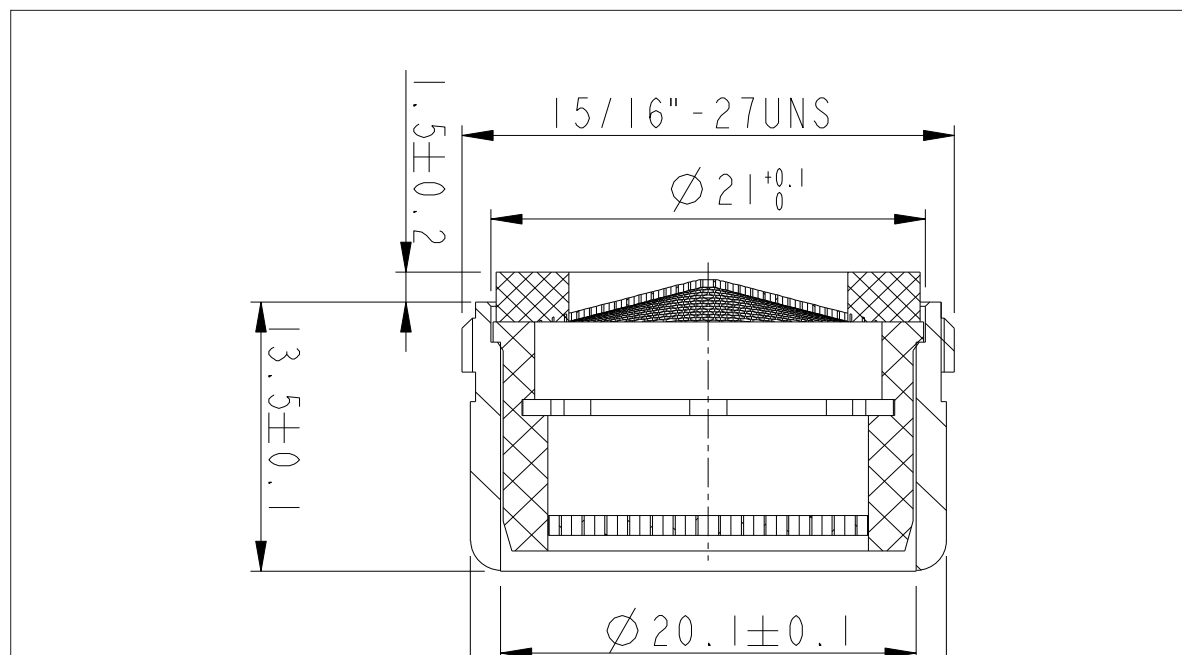

Product Spec Sheet