

TNS-A02 Pressure Balanced Valve Body Only



PRESSURE BALANCED VALVE BODY ONLY



Product Spec Sheet

FEATURES & BENEFITS

- Pressure Balanced Valve Body
- Temperature Limit Stop
- With Integral Stops
- Washerless Cartridge Assembly
- MIP And SWT Dual Connection
- Compatible For Back To Back Installation
- Chrome Finish
- 100% Factory Pressure Tested Before Shipment

* TNS-A02
Chrome Finish

APPROVALS:

Meets or Exceeds The Following:

- * ANSI/ASME A112.18.1
- * CSA B125.1
- * ANSI/NSF 61 – Sec. 9
- * IAPMO/UPC



ANSI/NSF 61
Section 9



BREWSTER, NY: TEL: 800-431-2082
HOUSTON, TX: TEL: 800-935-5456
LA PALMA, CA: TEL: 866-532-8306

FAX: 800-640-2252
FAX: 800-683-4247
FAX: 866-832-8307

Visit Our Web Site : www.matco-norca.com

TNS-A02 Pressure Balanced Valve Body Only



| No | Part Title | Material |
|----|-------------------------------|-----------------|
| 1 | Screw(3/16" -24 * 2-3/16" L) | Stainless Steel |
| 2 | Plaster Guard | ABS |
| 3 | Sleeve | ABS |
| 4 | Retainer Nut | Brass |
| 5 | Washerless Cartridge Assembly | Brass & Plastic |
| 6 | Temperature Limiting Device | Plastic |
| 7 | Pressure Balancing Insert | Brass & Plastic |
| 8 | Seat | Rubber |
| 9 | Spring | Stainless Steel |
| 10 | O-Ring(1-3/8" ID * 1-1/2" OD) | Plastic |
| 11 | Cap | Brass |
| 12 | Piston & Cylinder Assembly | Brass & Rubber |
| 13 | O-Ring(9/16" ID * 11/16" OD) | Rubber |
| 14 | O-Ring(7/16" ID * 9/16" OD) | Rubber |
| 15 | O-Ring(3/8" ID * 1/2" OD) | Rubber |
| 16 | O-Ring(3/8" ID * 1/2" OD) | Rubber |
| 17 | Integral Stops | Brass & Rubber |
| 18 | Plug | Brass |
| 19 | Body | Brass |

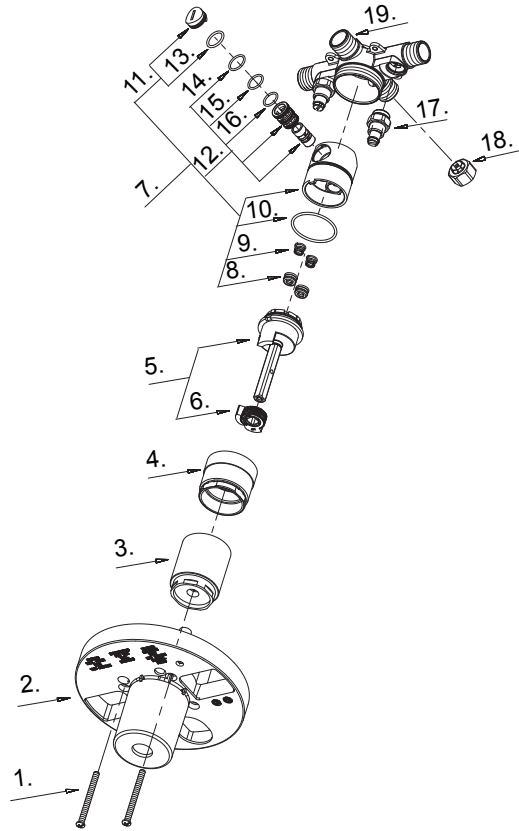

Product Spec Sheet

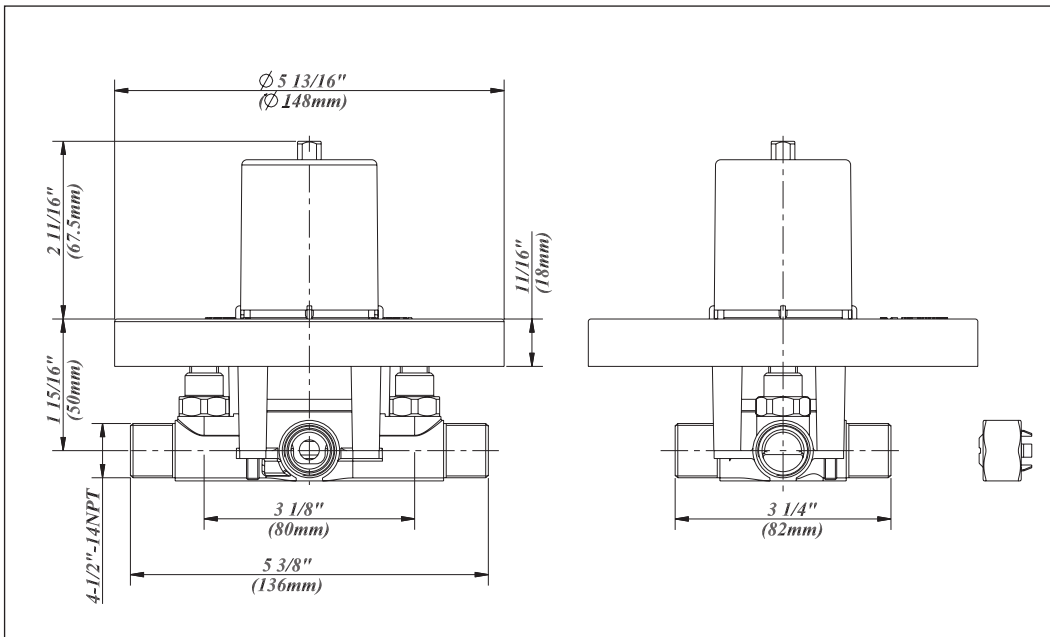

APPROVALS:
Meets or Exceeds
The Following:

- * ANSI/ASME A112.18.1
- * CSA B125.1
- * ANSI/NSF 61 – Sec. 9
- * IAPMO/UPC



BREWSTER, NY: 1944 Route 22 Brewster, NY 10509
HOUSTON, TX: 1150 Silber Road Houston, TX 77055
LA PALMA, CA: 5593 Fresca Drive La Palma, CA 90623

Visit Our Web Site : www.matco-norca.com