

200WW Ductile Iron Gate Valve

Specification Sheet

FEATURES & BENEFITS

- Gate Valve - Flanged Ends
- 200 CWP - Max. Temp. 180 Deg. F.
- AWWA C550 Fusion Bonded Epoxy
- EPDM Resilient Wedge
- Non Rising Stem
- Manufactured to AWWA C509-15
- Flanged End Conforms with ASME B16.1

MATERIAL SPECIFICATIONS

No.	Part	Material
1	Valve Body	Ductile Iron ASTM A536
2	Resilient Wedge	Ductile Iron ASTM A536/ EPDM ASTM D2000
3	Stem Nut	Bronze ASTM B584
4	Stem	Stainless Steel AISI 410
5	Bonnet	Ductile Iron ASTM A536
6	Stem Primary O-Ring	EPDM ASTM D2000
7	Stem Gasket	NYLON 1010
8	Gland Seal O-Ring	EPDM ASTM D2000
9	Stem Secondary O-Ring	EPDM ASTM D2000
10	Stem Seal Bushing	NYLON 1010
11	Packing Gland	Ductile Iron ASTM A536
12	Wiper Ring	EPDM ASTM D2000
13	Operating Nut	Cast Iron ASTM A126-B
14	Washer	Stainless Steel AISI 410
15	Bolts	Stainless Steel AISI SS304
16	Gland Bolts	Stainless Steel AISI SS304
17	Bonnet Gasket	EPDM ASTM D2000
18	Bonnet Bolt	Stainless Steel AISI SS304



Valve comes standard with wheel handle.
2" Op Nut available upon request.

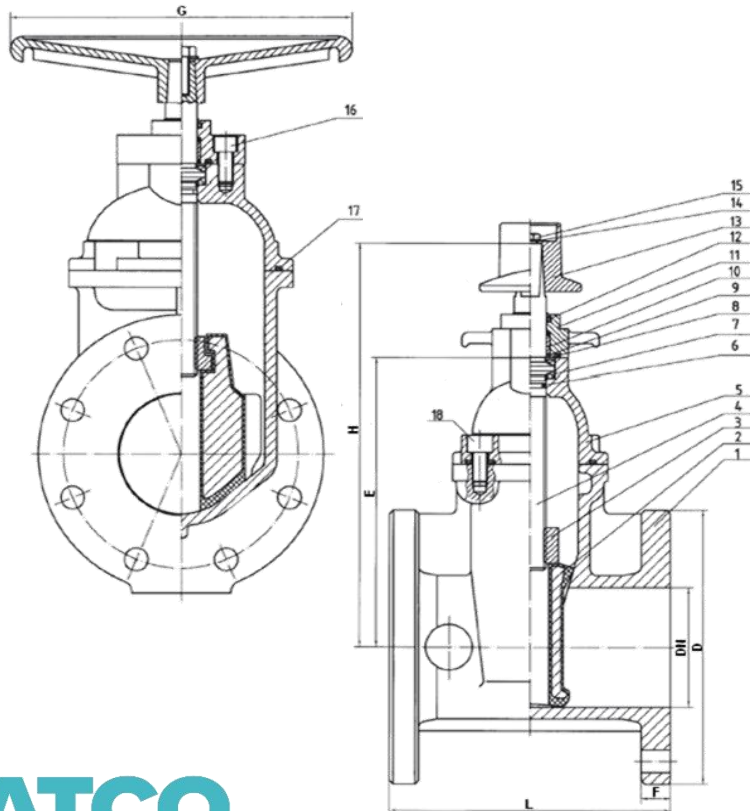

DIMENSIONS

Size DN	L	F	D	E	H	G
2"	7.00	0.63	6.00	6.30	10.80	7.88
3"	8.00	0.75	7.50	8.35	12.85	10.24
4"	9.00	0.95	9.00	9.69	14.18	10.24
6"	10.50	1.00	11.00	13.00	17.61	14.78
8"	11.50	1.13	13.50	16.15	20.92	14.78
10"	13.00	1.19	16.00	13.00	17.61	15.76
12"	14.00	1.26	19.00	16.15	20.92	19.70

