

□ **LV-250CB**

**MATCO
NORCA**

Two - Handle Kitchen Faucet

Product Spec Sheet



FEATURES & BENEFITS

LV-250CB
Chrome Finish

- This Product Contains Less Than 0.25% Weighted Average Lead Content On Wetted Surfaces
- Metal Lever Handle
- Washerless Cartridge
- Max Flow Rate 1.5 GPM (5.7L/Min) At 60 PSI (ASME A112.18.1/A112.18.1)

Approvals:

Meets or Exceeds The Following:

- * ANSI/ASME A112.18.1/A112.18.1
- * NSF/ANSI 61 - Sec. 9
- * NSF/ANSI 372
- * IAPMO/cUPC
- * CA AB1953
- * ADA Compliant
- * NSF/ANSI/CAN 61: $Q \leq 1$



TEL: 800-431-2082

FAX: 800-640-2252

Visit Our Web Site : www.matco-norca.com

Two - Handle Kitchen Faucet

No.	Name	Part No.
1	Index H / <i>índice H</i>	RP10008
2	Index C / <i>índice C</i>	RP10009
3	Handle H / <i>Llave H</i>	RP13633*
4	Handle C / <i>Llave C</i>	RP13634*
5	Bonnet / <i>Bonete</i>	RP70678
6	Washer / <i>Arandela</i>	RP64123
7	Screw / <i>Tornillo</i>	RP50212
8	Cartridge / <i>Cartucho</i>	RP22010
9	Seat & Spring / <i>Base y resorte</i>	RP22008
10	Gasket / <i>Junta</i>	RP80700
11	Aerator / <i>Aireado</i>	RP30094*
12	Easy install nut / <i>Tuerca fácil de instalar</i>	RP56095
13	Coupling nut / <i>Tuerca de acoplamiento</i>	RP56002

* Specify Finish
* Especifique el Acabado

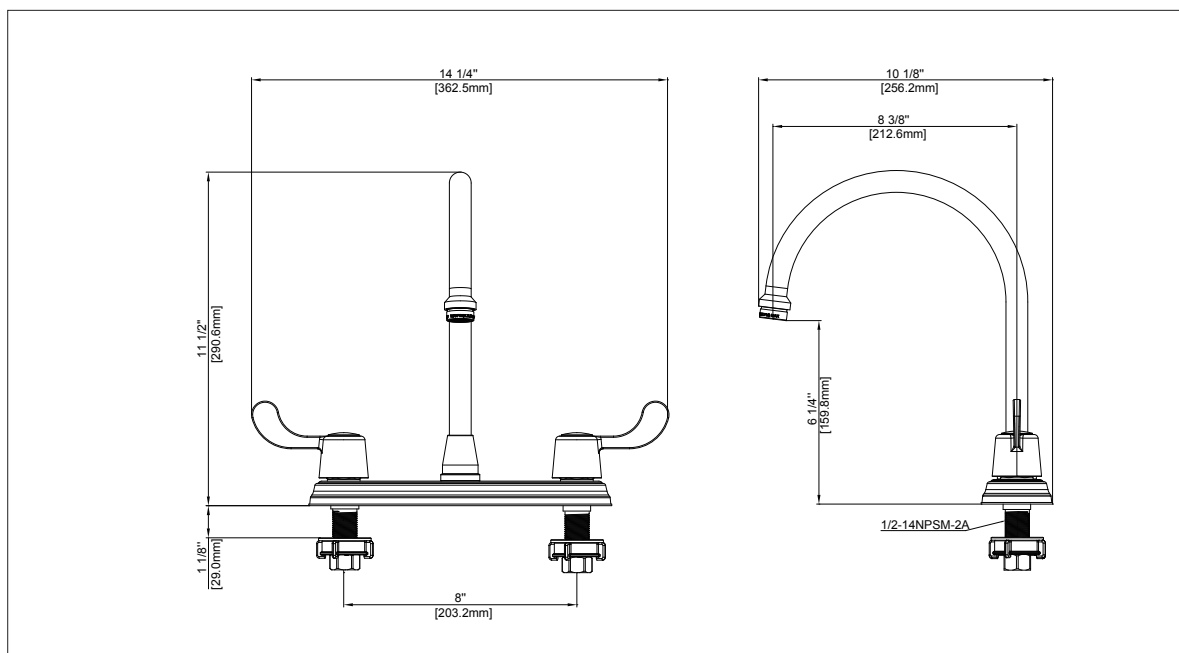

Product Spec Sheet