

LF Dielectric Union - Female X Sweat

Specification Sheet

FEATURES & BENEFITS

- Lead Free Brass
- 250 PSI @ 80°F; 125 PSI @ 180°F
- Sizes 1/2" - 2"



MATERIAL SPECIFICATIONS

No.	Part	Material
1	IPS Connection	Zinc Coated Cast Steel
2	Nut	Zinc Coated Cast Steel
3	Gasket	EPDM
4	Solder Connection	Brass
5	Insert	Nylon

DIMENSIONS

Part #	Size	A	B	C	D	E
DUN-0509LF	1/2"	1.42	1.00	0.77	1.87	0.83
DUN-7559LF	3/4" x 1/2"	1.62	1.26	0.77	1.87	0.83
DUN-0759LF	3/4"	1.62	1.26	0.77	2.11	1.06
DUN-1009LF	1"	1.89	1.50	0.87	2.32	1.30
DUN-1259LF	1-1/4"	2.25	1.81	0.91	2.58	1.58
DUN-1509LF	1-1/2"	2.76	2.13	0.95	2.80	1.81
DUN-2009LF	2"	3.51	2.60	1.06	3.11	2.36

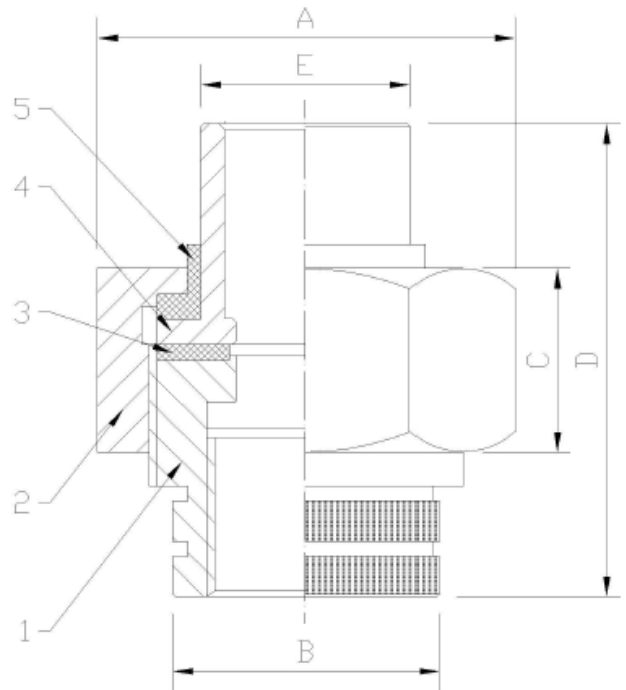

LF Dielectric Union - Male X Sweat

Specification Sheet

FEATURES & BENEFITS

- Lead Free Brass
- 250 PSI @ 80°F; 125 PSI @ 180°F
- Sizes 1/2" & 3/4"



MATERIAL SPECIFICATIONS

No.	Part	Material
1	IPS Connection	Zinc Coated Cast Steel
2	Nut	Zinc Coated Cast Steel
3	Gasket	EPDM
4	Solder Connection	Brass
5	Insert	Nylon

DIMENSIONS

Part #	Size (F)	A	B	C	D	E	G
DUN-0509MLF	1/2"	1.42	1.00	0.77	2.78	0.83	0.63
DUN-759MLF	3/4"	1.62	1.26	0.77	3.05	1.06	0.88

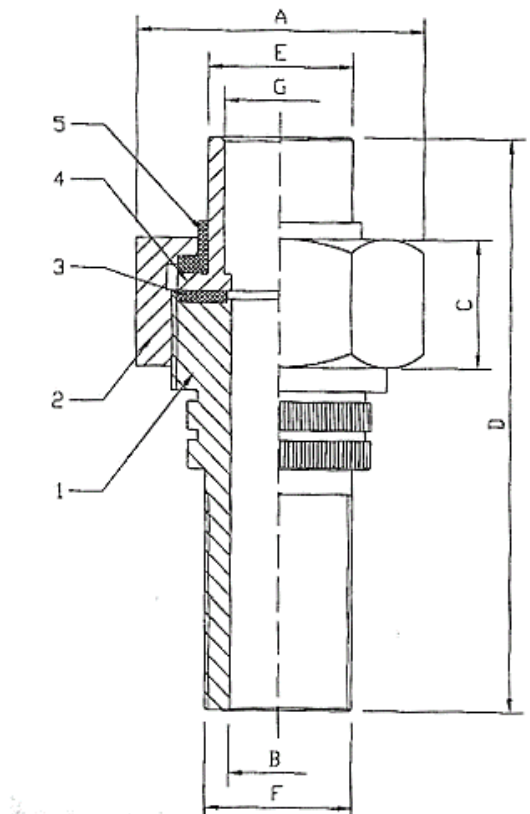

LF Dielectric Union - Female X Female

Specification Sheet

FEATURES & BENEFITS

- Lead Free Brass
- 250 PSI @ 80°F; 125 PSI @ 180°F
- Sizes 1/2" - 2"

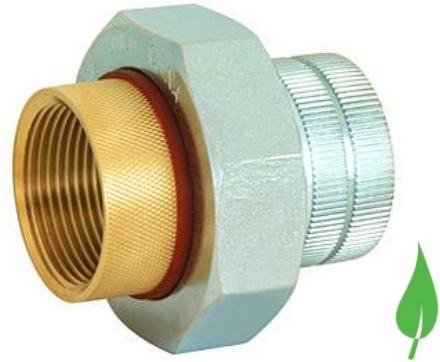

MATERIAL SPECIFICATIONS

No.	Part	Material
1	IPS Connection	Zinc Coated Cast Steel
2	Nut	Zinc Coated Cast Steel
3	Gasket	EPDM
4	IPS Connection	Brass
5	Insert	Nylon

DIMENSIONS

Part #	Size	A	B	C	D	E
DUN-EA03LF	1/2"	1.62	1.02	0.77	2.21	1.02
DUN-EA04LF	3/4"	1.89	1.26	0.77	2.21	1.26
DUN-EA05LF	1"	2.25	1.50	0.87	2.52	1.46
DUN-EA06LF	1-1/4"	2.76	1.81	0.91	2.72	1.85
DUN-EA07LF	1-1/2"	3.51	2.13	0.91	2.76	2.13
DUN-EA08LF	2"	4.14	2.60	1.10	3.11	2.60

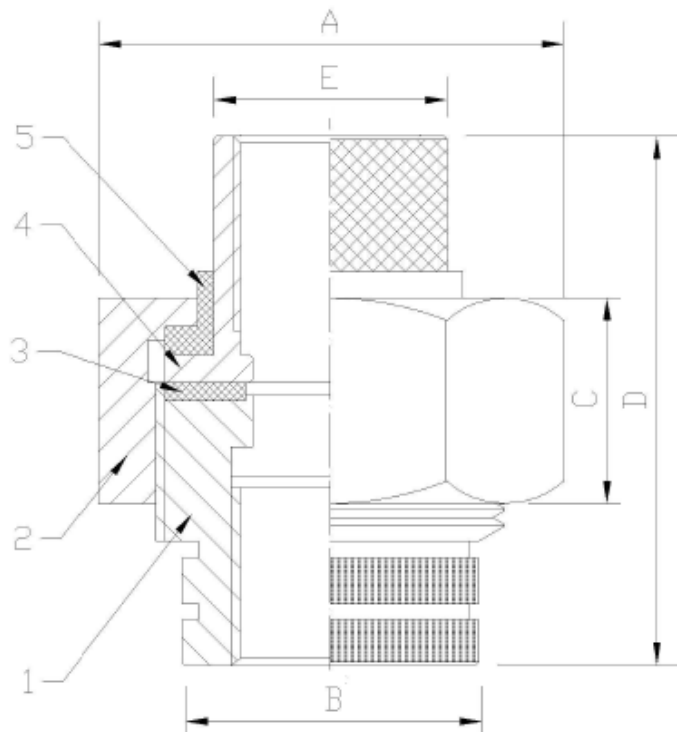

LF Dielectric Union - Female X SWT

Specification Sheet

FEATURES & BENEFITS

- Lead Free Brass
- 250 PSI @ 80°F; 125 PSI @ 180°F
- Sizes 2-1/2" - 3"



MATERIAL SPECIFICATIONS

No.	Part	Material
1	Bolts	Zinc Coated Steel
2	Nuts	Zinc Coated Steel
3	Flange	Cast Iron W/ Galvanized
4	Gasket	EPDM
5	Flange	Cast Iron W/ Galvanized
6	Insulator	Nylon
7	Solder Connection	Lead Free Brass

DIMENSIONS

Part #	Size	A	B
DUN-0909LF	2-1/2"	3.54	6.11
DUN-1010LF	3"	3.74	6.70

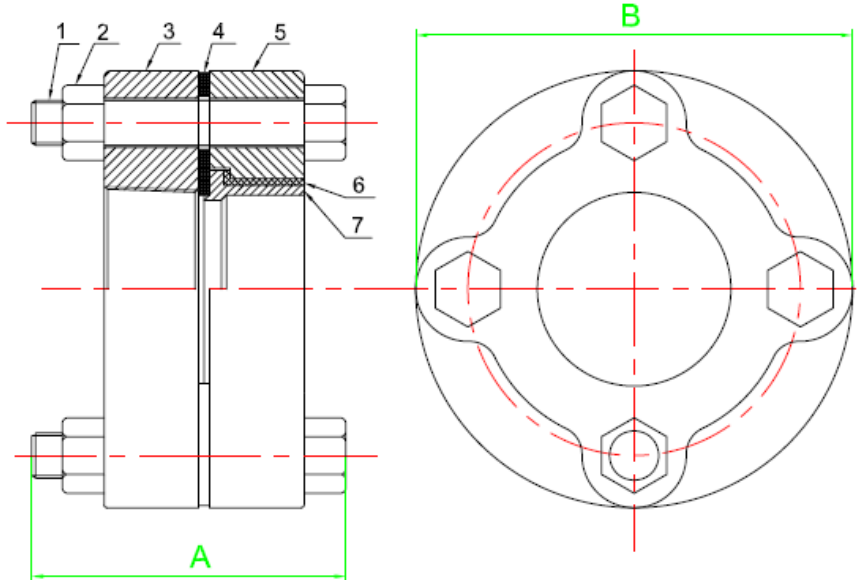

LF Dielectric Union - Female X SWT

Specification Sheet

FEATURES & BENEFITS

- Lead Free Brass
- 250 PSI @ 80°F; 125 PSI @ 180°F
- Sizes 4"



MATERIAL SPECIFICATIONS

No.	Part	Material
1	Bolts	Zinc Coated Steel
2	Nuts	Zinc Coated Steel
3	Plastic Gasket	EPDM
4	Flange	Brass
5	Rubber Washer	Nylon
6	Flange	Zinc Coated Cast Iron

DIMENSIONS

Part #	Size	A	B	D
DUN-1111LF	4"	9.14	4.53	2.19

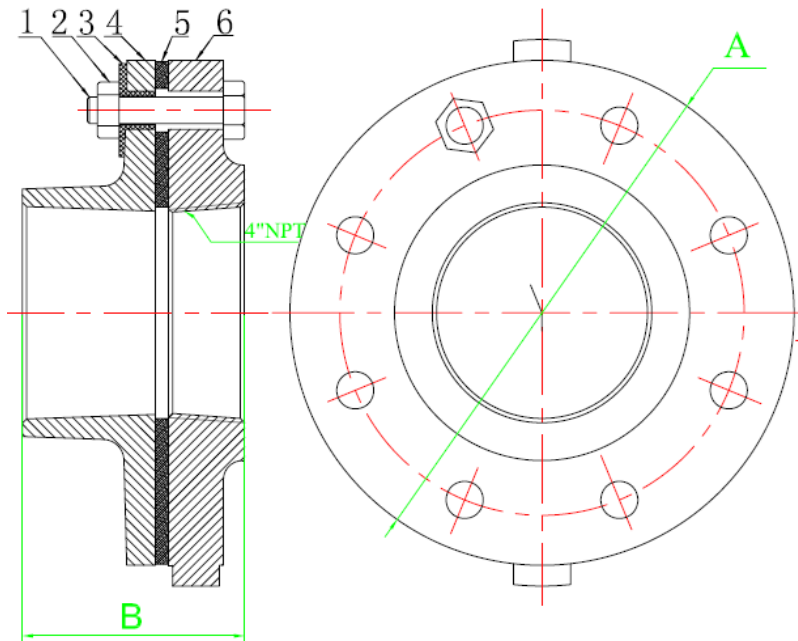

LF Dielectric Union - Female X Female

Specification Sheet

FEATURES & BENEFITS

- Lead Free Brass
- 250 PSI @ 80°F; 125 PSI @ 180°F
- Sizes 2-1/2" - 4"

MATERIAL SPECIFICATIONS

No.	Part	Material
1	Flange	Cast Iron W/ Galvanized
2	Gasket	EPDM
3	Flange	Lead Free Bronze
4	Insulator	Nylon
5	Bolts	Zinc Coated Steel

DIMENSIONS

Part #	Size	A	B
DUN-GA09LF	2-1/2"	2.36	7.01
DUN-GA10LF	3"	2.52	7.53
DUN-GA11LF	4"	2.76	9.14

